



ASSEMBLY / OPERATOR'S MANUAL



GMD 802 - 902 Multidisc Mower



PLEASE READ CAREFULLY
BEFORE USING THE MACHINE

DEAR OWNER,

In buying a **KUHN** machine you have chosen wisely. Into it have gone years of thought, research and improvements. You will find, as have thousands of owners all over the world, that you have the best that engineering skill and actual field testing can produce. You have purchased a dependable machine, but only by proper care and operation can you expect to receive the performance and long service built into it.



This manual contains all the necessary information for you to receive full efficiency from your machine. The performance you get from this machine is largely dependant upon how well you read and understand this manual and apply this knowledge. Please **DO NOT ASSUME THAT YOU KNOW HOW TO OPERATE AND MAINTAIN YOUR MACHINE** before reading this manual carefully. **KEEP THIS MANUAL AVAILABLE FOR REFERENCE.**

Your **KUHN** dealer will instruct you on the general operation of your machine. He is interested that you get the best performance possible and will be glad to answer any special questions that may arise regarding the operation of the **KUHN** machine.

Your **KUHN** dealer can offer a complete line of genuine **KUHN** service parts. These parts are manufactured and carefully inspected in the same factory that builds the machine to assure high quality and accurate fitting of any necessary replacements.

When ordering service parts it is important that you indicate the type of machine concerned and its serial number.

For this reason please complete the model identification plate diagram below with the required information. This will provide you with an easy reference for future service parts orders.

	KUHN S.A.
	67700 SAVERNE - FRANCE
TYPE _____	N° _____
MASSE XXXX kg	
	
*XXXXXXXX XXXXX *	MADE IN FRANCE

ABOUT IMPROVEMENTS

KUHN is continually striving to improve its products and, therefore, reserves the right to make improvements or changes when it becomes practical to do so, without incurring any obligations to make changes or additions to the equipment sold previously.

CONTENTS

	Page
Safety	2
Safety decals - Model identification plate	8
Technical specifications	11
Assembly	12
Lower hitch pin adjustment	16
Coupling to the tractor	18
Adjustment of chassis height from the ground	20
Primary P.T.O. shaft	21
Secondary P.T.O. shaft	22
Working position	23
Transport position	24
Adjustments	25
1. Adjustment of the cutting height	25
2. Adjustment of the swath wheels	25
3. Adjusting the pressure on the ground and the safety breakback	26
4. Adjustment of the mowing unit stabilising pressure	27
Parking the machine	28
Operating the multidisc mower	30
Maintenance	31
Access to cutterbar	34
Knives and discs	35
Lubrication	39
Optional equipment	44
Storing the multidisc mower	44
Trouble shooting guide	45
Limited warranty	46

SAFETY



The above symbol is used throughout this manual every time recommendations are made concerning your safety, the safety of others, or the good operation of the machine.

These recommendations must be made known to all machine operators.

DESIGNATED USE OF THE MACHINE

GMD 802 - 902 Multidisc mowers must only be used for the work which they have been designed : mowing on the ground of hay fields, grass silage fields and improved pastures for the purpose of harvesting fodder for feeding livestock.

The manufacturer is not held liable for any damage resulting from machine applications other than those specified by the manufacturer.

Any use other than the designated operation is at the risk and responsibility of the operator.

Designated use of the machine also means :

- following operation, maintenance and repair recommendations given by the manufacturer ;
- using only genuine spare parts, equipment and accessories as designated by the manufacturer.

GMD 802 - 902 Multidisc mowers must only be operated, maintained and repaired by competent persons who are familiar with machine specifications and operation and are aware of any danger involved.

The operator must imperatively respect current legislation concerning :

- accident prevention,
- work safety,
- public traffic circulation.

All safety advice indicated on the machine must be strictly observed.

The manufacturer is not held liable for any damage resulting from machine modifications carried out by the operator himself or by a third party without previous written agreement from the manufacturer.

GENERAL SAFETY RECOMMENDATIONS

Before operating the machine, always ensure that tractor and machine are in accordance with work safety and road traffic regulations.

GENERAL SAFETY RECOMMENDATIONS

Before operating the machine, always ensure that tractor and machine are in accordance with work safety and road traffic regulations.

BASIC PRINCIPLES

1. In addition to the recommendations given in this manual, legislation on work safety and accident prevention must also be respected.
2. Advice is indicated on the machine, specifying safety recommendations in order to prevent accidents.
3. Before travelling on public roads, the operator must ensure that the machine conforms to road traffic regulations.
4. Before starting work, the operator must be familiar with all machine controls, handling devices and their functions. Once at work, it is too late to do so !
5. Use a tractor equipped with a safety cab. Keep windows and roof hatch closed for reduced sound level while operating the PTO driven implement.
6. Before starting up the machine and beginning work, check the surrounding area (beware of children !). Make sure there is sufficient visibility. Keep all people and animals away from the danger zone of the machine (risk of projection!).
7. Carrying people or animals on the machine when working or in transport is strictly forbidden.
8. Machine must only be attached to tractor using means provided and in accordance with current safety standards.
9. When attaching or removing the machine, place the parking stand into the corresponding position.
10. Special care should be taken when attaching or removing the machine from the tractor.
11. Before attaching the machine, ensure that the front tractor axle is sufficiently ballasted. Ballast is to be placed on the supports provided in accordance with instructions of the tractor manufacturer.
12. Do not surpass the maximum axle load or the overall transport weight as prescribed by the tractor manufacturer.
13. Do not surpass the maximum transport width authorized by road traffic regulations.
14. Before transporting the machine on public roads, ensure that all legally required guards and indicators (lights, reflectors ...) are in place and in good operation.
15. All operating controls (cords, cables, rods ...) must be positioned so that they cannot be set off accidentally, risking accident or damage.
16. Before transport on public roads, locate the machine into its transport position as instructed in this operator's manual.
17. Never leave the tractor seat while the machine is operating.

18. Drive speed must be adapted to ground conditions as well as roads and paths.
Always avoid abrupt changes of direction.
19. Precision steering, tractor adherence, road holding and efficient braking are influenced by the type of implement, weight, ballast of front axle, ground or road conditions. It is therefore of utmost importance to be cautious in every given situation.
20. Be particularly cautious when turning corners, paying attention to machine overhang, length, height and weight.
21. Keep clear of the machine operating area.
22. **WARNING !** Danger of crushing and shearing can exist when components are operated by hydraulic or pneumatic controls.
23. Before leaving the tractor or before adjusting, maintaining or repairing the machine, turn off the engine, remove ignition key and wait until all moving parts have come to a complete stop.
24. Do not stand between the tractor and the machine unless the hand brake is tight and/or stops have been placed under the wheels.
25. Before any adjustments, maintenance or repairs are carried out, ensure that the machine cannot be started up accidentally.

PRECAUTIONS TO BE TAKEN BEFORE OPERATING THE MACHINE

1. Do not wear loose clothing which could be caught up in moving parts.
2. Wear the individual protection equipment corresponding to the work which is planned (gloves, shoes, eye protection, helmet, ear protectors...).
3. All operating controls (cords, cables, rods ...) must be positioned so that they cannot be set off accidentally, causing accident or damage.
4. Before operating the machine, check the tightness of all nuts and bolts, particularly on rotating parts (blades, tines, knives, spades ...)
5. Before operating the machine, ensure that all safety guards are firmly in place and in good condition. If worn or damaged, replace immediately.

ATTACHMENT

1. When attaching or removing the machine from the tractor, position hydraulic lift control lever in such a way that it cannot be set off accidentally.
2. **WARNING !** Danger of crushing and shearing can exist in the lifting zone of the 3-point linkage !
3. Do not stand between the tractor and the machine when operating the outer control lever of the lift mechanism.
4. In transport, the machine lift mechanism should be stabilized by tractor tie rods to avoid floatation and side shifting.
5. When transporting the machine in the raised position, lock the lift control lever in place.

POWER TAKE-OFF

1. Only use PTO shaft supplied with the machine or recommended by the manufacturer.
2. PTO guards must always be in place and in good condition.
3. Check for correct PTO overlap when at work and in transport.
4. Before attaching or removing the PTO shaft, disengage PTO shaft, turn off engine and remove ignition key.
5. If a primary PTO shaft is equipped with a slip clutch or a free wheel, these must be fitted on the machine PTO.
6. Ensure that PTO shaft is always correctly fitted and locked into place.
7. Make sure guards are correctly in place and secured with the safety chains provided.
8. Before engaging PTO, ensure that PTO speed (*rotational frequency*) and direction of rotation are in accordance with manufacturer's recommendations.
9. Before engaging PTO, keep all people and animals clear from the machine.
10. Never engage PTO shaft when tractor motor is turned off.
11. Never surpass PTO angle recommended by the manufacturer.
12. **WARNING !** Rotating elements can continue turning momentarily after PTO is disengaged. Keep clear until all rotating elements are at a standstill.
13. When removing the machine, locate PTO shaft on the supports provided.
14. Fit safety cap on tractor PTO.
15. Replace any worn or damaged PTO guards immediately.

Rotation speed ... rpm (American Measure) is also expressed in metric measure : *Rotational frequency ... min⁻¹*
¹. Both units are equivalent, for example : Rotation speed 540 rpm equals *Rotational frequency 540 min⁻¹*.

HYDRAULIC SYSTEM

1. **WARNING !** Hydraulic system is under pressure (maximum working pressure : 200 bars/2900 psi).
2. When fitting hydraulic motors or cylinders, ensure that connections have been made correctly, as per manufacturer's instructions.
3. Before connecting hoses to the tractor hydraulics, ensure that tractor and machine circuits are not under pressure.
4. It is strongly recommended that the operator marks the hydraulic connections between tractor and machine to avoid making a wrong connection. **WARNING !** Functions could be reversed (for example : lift/lower).

5. Regularly check the hydraulic hoses ! Replace the hydraulic hoses every 5 years. Damaged or worn hoses must immediately be replaced .
When replacing the hydraulic hoses, make sure to use hoses with the specifications and quality recommended by the manufacturer of the machine.
6. Should a leak be found, take all necessary precautions to avoid accidents.
7. Any liquid under pressure (particularly oil from hydraulics) can penetrate the skin and cause severe injury. If injured, see a doctor immediately, there could be danger of infection.
8. Before any adjustments, maintenance or repairs are carried out, lower the machine, depressurize the circuit, turn off the engine and remove ignition key.

HYDRO-PNEUMATIC ACCUMULATOR

1. The hydro-pneumatic accumulator is gas pressurised. Any operation aimed at changing its exterior is strictly forbidden (soldering, grinding, drilling, etc...).
2. The hydro-pneumatic accumulator and its fastening must always be kept in good condition.

MAINTENANCE

1. Before checking any machine malfunction and before adjusting, maintaining or repairing the machine, disengage PTO, turn off engine and remove ignition key.
2. Check tightness of nuts and bolts regularly. Retighten if necessary.
3. If the machine is raised, prop it up in a stable position before carrying out any maintenance work.
4. When replacing a working part, wear protection gloves and only use standardized tools.
5. It is forbidden to discard any oil, grease or filters. These must be given to waste disposal organisations to protect the environment.
6. Disconnect power source before any work is done on the electric system.
7. Check safety guards regularly, particularly those that are subject to wear. Replace immediately if damaged.
8. Spare parts used must be in accordance with specifications and standards as defined by the manufacturer. Use only genuine KUHN parts !
9. Before any electric welding is carried out on tractor or attached machine, disconnect generator and battery terminals.
10. Repairs on elements under pressure or tension (springs, accumulators etc.) must only be carried out by competent persons with standardized equipment.

SPECIAL SAFETY RECOMMENDATIONS

1. Use a tractor equipped with an enclosed cab with windows made of safety glass and kept closed. It is recommended to fit polycarbonate screens inside the tractor safety cab's side and rear windows or to install mesh guards on the exterior of them.
2. Stay a safe distance away from the multidisc mower when discs are rotating.
3. For safe machine operation, it is imperative that cutting tools be fitted in accordance with the manufacturer's recommendations. Use only the tool outfit supplied with the machine.
4. Each time before using the multidisc mower, inspect condition of cutting elements (knives, discs). Replace any missing, worn or damaged cutting elements immediately. Use only genuine KUHN spare parts.
5. To avoid creating dangerous out of balance forces, always replace missing, damaged or worn knives in pairs.
6. When replacing knives or discs, systematically inspect their securing elements as per the manufacturer's recommendations.
7. Regularly inspect the multidisc mower's protection cover. Worn or damaged protection covers must be replaced immediately.
8. Protection devices (such as guards, shields etc.) are intended to prevent stones, rocks or other foreign objects from being projected. They also prevent access to the machine's danger zones. Therefore, it is imperative that protection devices are put in place and properly secured each time before using the machine.
9. Crushing and shearing zones which could cause serious bodily injury when changing the machine from transport to work position and vice versa may exist. To prevent possible injury, be extra careful when maneuvering and ensure that everyone is at a safe distance away from the machine.
10. PTO drive to the multidisc mower must never be engaged unless the cutterbar skid shoes are in contact with the ground and the protective cover is folded down.
11. Ground of the pastures to be mown must be free of foreign objects.
12. Even when the machine is used in accordance with its purpose, objects may be projected. It is therefore imperative that everyone be kept away from the danger zone, that extra care be taken and that extra precaution (such as safety indicators) be taken when mowing pastures alongside roads or near public areas (parks, schools etc.).
- 13. Never mow in reverse.**
14. When disengaging the PTO drive, moving parts continue to rotate for some time. Wait for all moving parts to come to a complete stop before approaching the machine.
15. If an obstruction is hit, stop the tractor immediately, disengage PTO drive, turn off engine, remove ignition key and wait for all moving parts to come to a complete stop.
Check the entire machine for any damage before resuming work.
16. It is strongly recommended to have your machine checked by your dealer after each season, especially blades and discs and their fixing devices (nuts, bolts etc.).

SAFETY DECALS MODEL IDENTIFICATION PLATE

The following safety pictorials have been placed on your machine in the areas indicated. They are intended for your personal safety and for the safety of the people working with you. The text shown on them gives their precise meaning. Keep the pictorials clean. Replace them when they are faded, in particular the signalling panel (9) situated on the end of the machine.

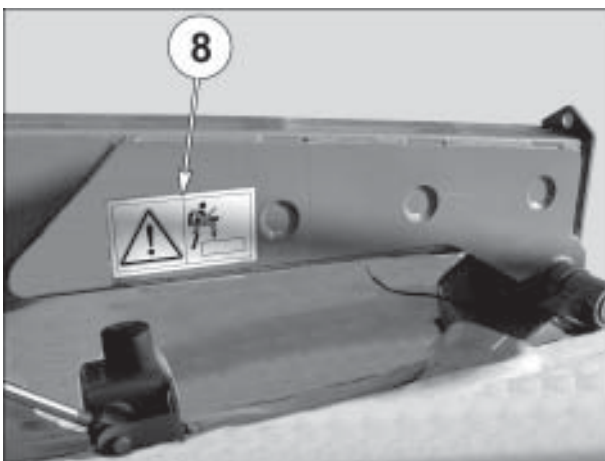
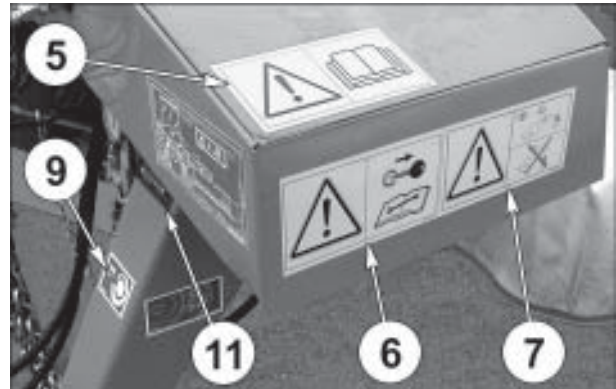

①

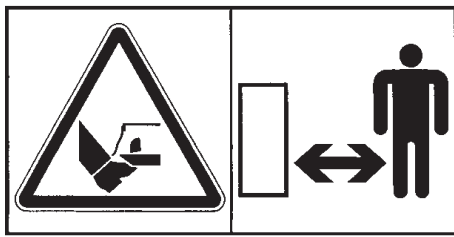

ROTATING TOOLS !
Stay clear of mower knives as long as engine is running with PTO connected.

59900800



⚠ WARNING

ROTATING TOOLS
STAY CLEAR OF MOWER KNIVES AS LONG AS TRACTOR ENGINE IS RUNNING WITH PTO CONNECTED

59900820

②



ROTATING TOOLS !
Objects and debris can be thrown a long distance.
Keep a safe distance from the machine.

599 002 00



⚠ WARNING

ROTATING TOOLS
OBJECTS AND DEBRIS CAN BE THROWN A LONG DISTANCE.
KEEP A SAFE DISTANCE FROM THE MACHINE.

599 002 20

③

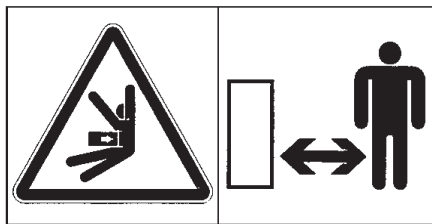

CRUSHING HAZARD ! STAY A SAFE DISTANCE FROM THE MACHINE.

59900600



⚠ WARNING

CRUSHING HAZARD
STAY A SAFE DISTANCE FROM THE MACHINE.

599 006 20

④

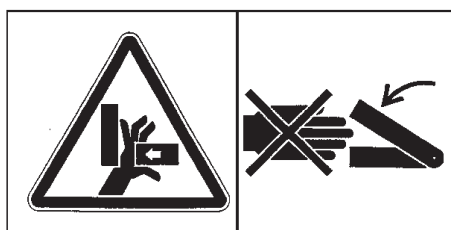

Never reach into the crushing area as long as parts may move

59900300

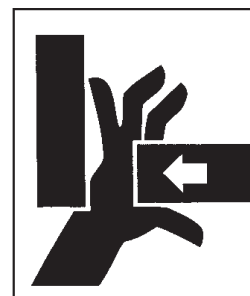

⚠ CAUTION

NEVER REACH INTO THE CRUSHING DANGER AREA AS LONG AS PARTS MAY MOVE

599 003 20

⑤

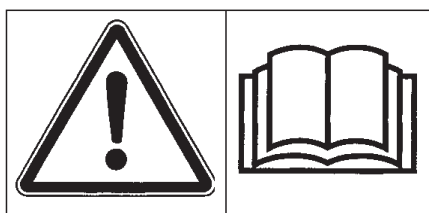

Before starting the machine, read operator's manual and safety instructions.

599 000 00

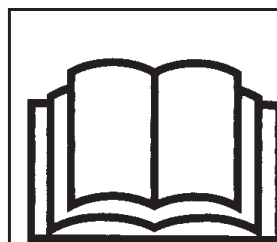

⚠ CAUTION

BEFORE STARTING THE MACHINE READ OPERATOR'S MANUAL AND SAFETY INSTRUCTIONS. REQUEST COPY IF NOT SUPPLIED.

599 000 20

6

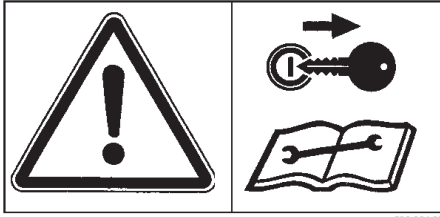

599 004 00

Before adjusting, maintaining and repairing the machine, turn off the engine, remove ignition key and wait until all moving parts have come to a complete stop.

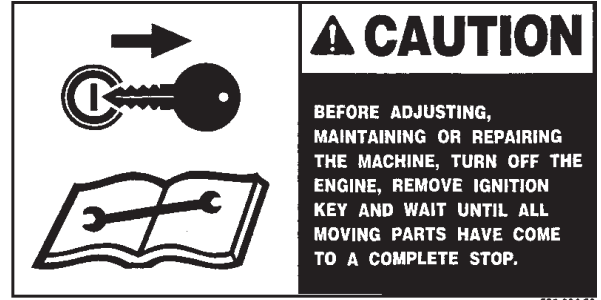

599 004 20

7

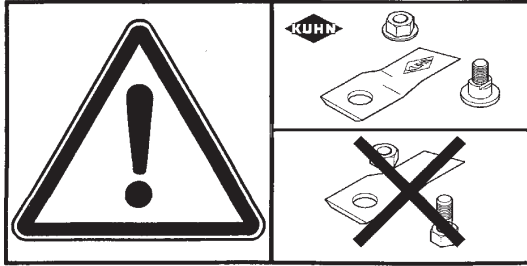

599 011 01

Use only genuine KUHN service parts

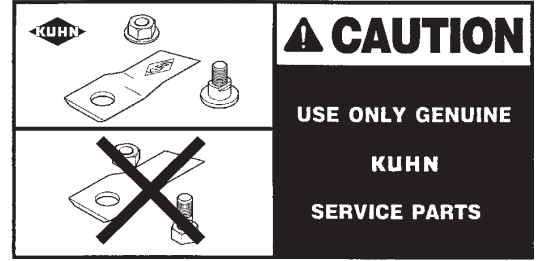

599 011 21

8



59901200

CAUTION!
Do not step on the machine.

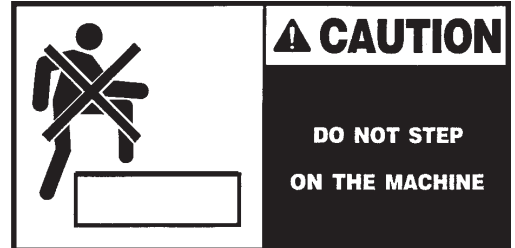

599 012 20

9



10



11

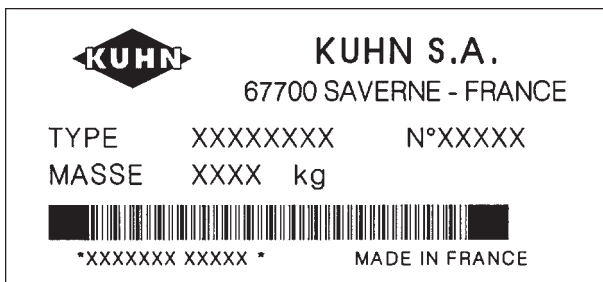

TECHNICAL SPECIFICATIONS

TYPE	GMD 802	GMD 902
Number of discs	8	9
Width of cut	3,11 m / 10' 2"	3,52 m / 11' 6"
Width in transport position (1)	+ 105 mm / 4" + 130 mm / 5" wider than tractor width	
Disc speed (<i>rotational frequency</i>)	2 986 rpm (<i>min⁻¹</i>)	
P.TO. speed (<i>rotational frequency</i>)	1000 rpm (<i>min⁻¹</i>)	
Primary P.TO. shaft (2)	1 3/8" 6 splines	
Weight (approx.)	800 kg (1760 lbs)	890 kg (1958 lbs)
Hydraulic outlets required	1 double acting valve 1 single acting valve with float detent	
Electric connection required	1 x 7 pin plug	
Tractor DIN power requirement (as from)	51 kW (70 hp)	59 kW (80 hp)
Tractor attachment	3 point - cat. 2	

(1) Applicable if machine is attached in such a way that a 5 cm / 2" distance "A" is respected (see page 17).

(2) For tractors with 1 3/8" - 21 splines PTO shafts a specific yoke is available on request (see optional equipment).

ASSEMBLY

To facilitate shipping, certain parts or assemblies are partially disassembled to reduce bulk.

For an easier handling of the machine when making unloading manoeuvres, the cylinder (B) has been replaced by a fixed rod (A) (photo 1).

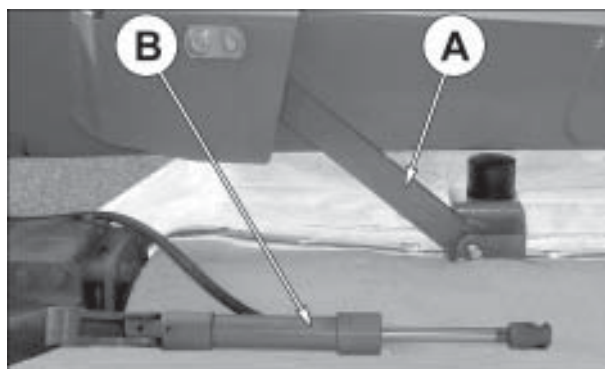

Once the unloading manoeuvres are completed, remove the fixed rod (A) and replace by the single acting cylinder (B) (photo 2).

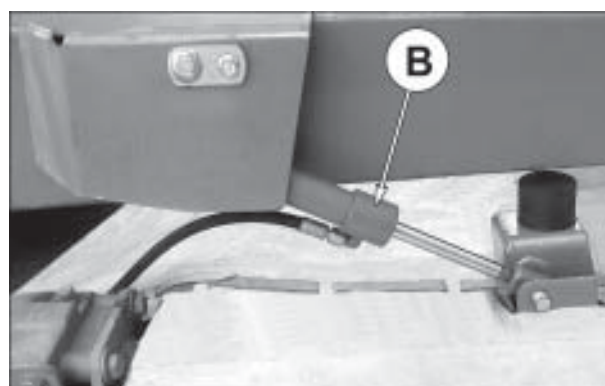

To assemble the partially disassembled parts proceed as follows :



IMPORTANT

Slide the electric cable through the protection cover sheath (1) so that the female terminal (2) is located at the tail light side and the male terminal (3) is located at the cutterbar central articulation side (photo 3).

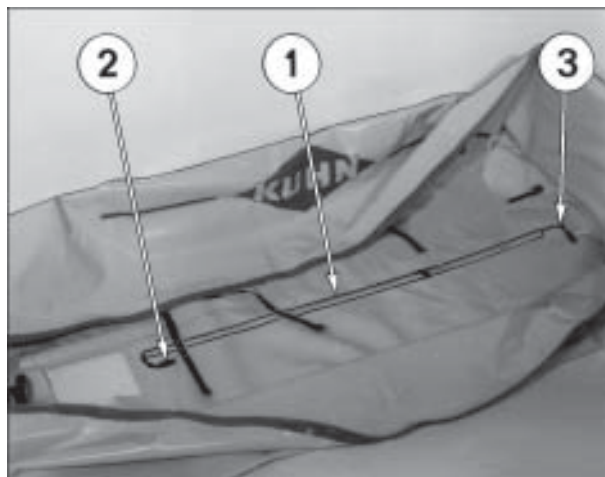

Slide straps (X) in the eyelets provided (photo 4). The long straps across the curtain centre line and the shorter straps on the peripheral eyelets.



1. Fitting the protection cover

- Lower the front protector
- The protection cover is pulled on like a "skirt"; match up the different cuts, in particular that of the unlocking latch (4) on the front protector (photo 2). Close the cover using strap (5) and fold it back to the end of the cover (photo 7).
- Close the cover using strap (5) (photo 5).

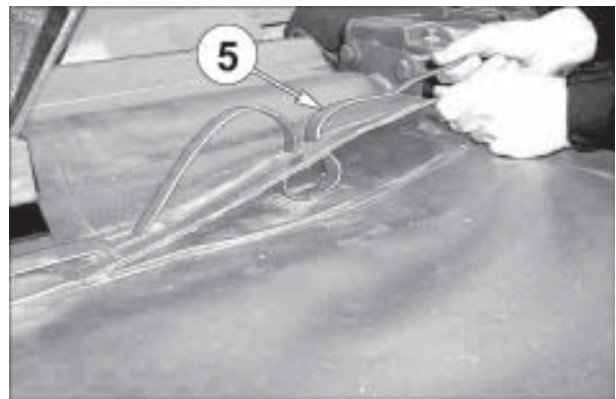

5

- Fold back the end of strap (5) (photo 6).

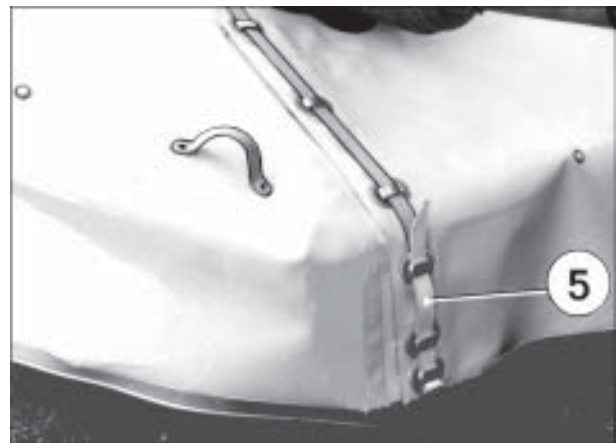

6

- Buckle the straps around frame tubes at (E) ; (F) and (G) (photos 7 and 8).
The short straps are located at (E) and (G).
The longer straps are located at (F).

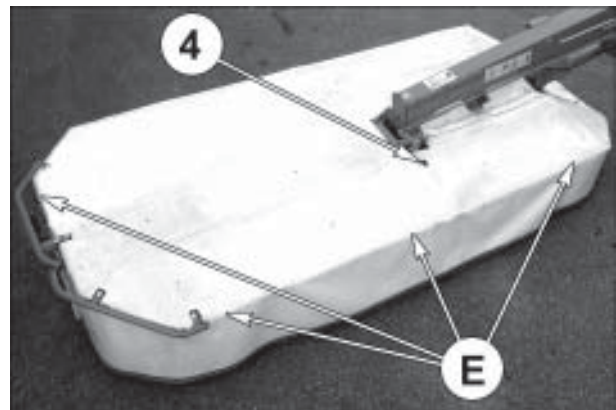

7

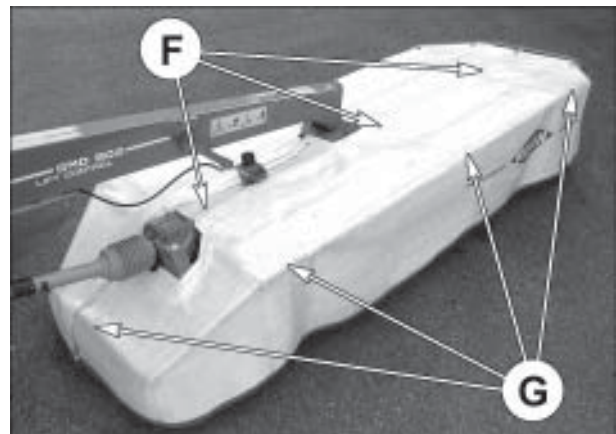

8

2. Fitting the safety guards

- Slide the safety guards (8 and 9) onto the frame tube and fix them using 5 cup square bolts (10) (M 10 x 50) and 5 self locking nuts (M 10) (photo 9).

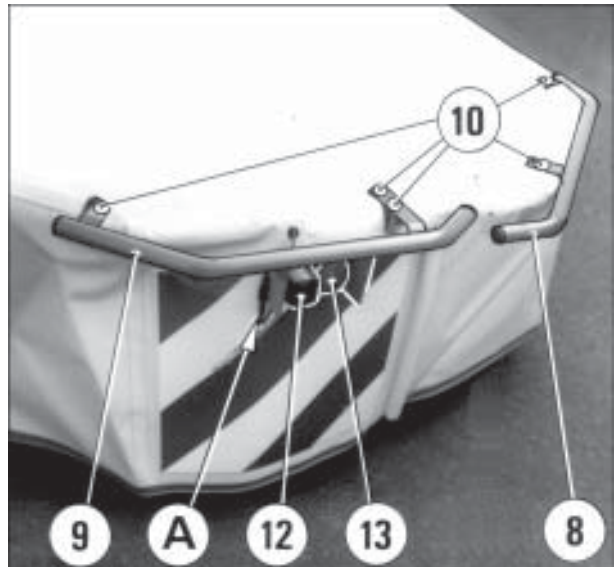

9

- Mount the rear light (12) and the reflector (13) on the safety guard (9) as shown on photo 9.

- On machines for North America, bolt reflector holders (8' and 9') and the SMV emblem mounting bracket (11) onto the frame tube. Secure in place using 3 cup square bolts (10) (M 10 x 50), 2 cup square bolts (13) (M 10 x 60) and 5 self locking nuts (M 10) (photo 9A).

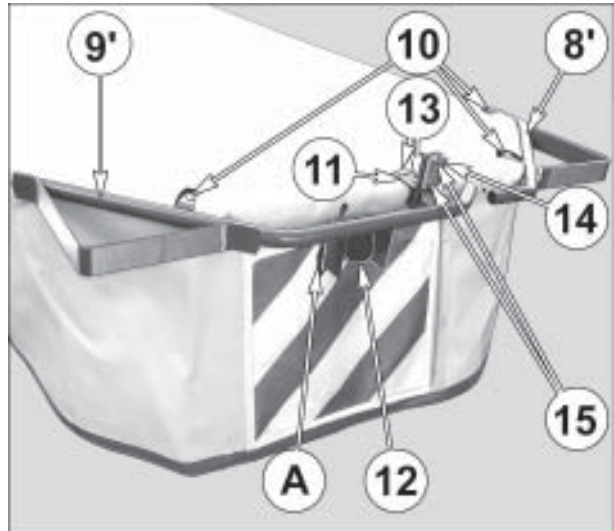

9A

- Bolt the SMV bracket (14) on mounting bracket (11) using 2 self locking screws (15) (M 10 x 20) and 2 self locking nuts (M 10) (photo 9A).
- Mount the rear light (12) and the reflector (13) on the safety guard (9) as shown on photo 9.

- Connect terminals located at the cutterbar central articulation at "A" (photo 10) and terminals located at the signalling light at "B" (photo 9).

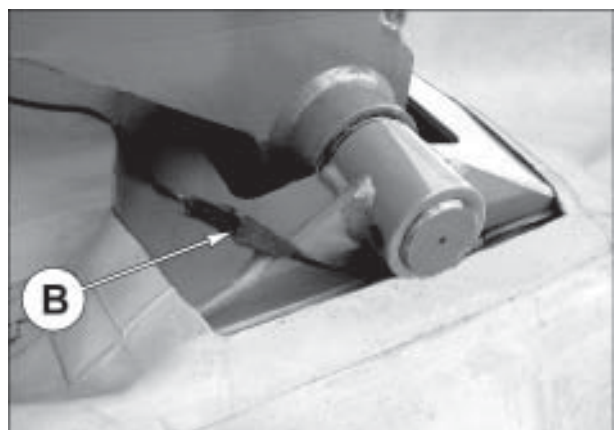

10



ATTENTION

Before driving onto a main road, check the cleanness of the signalling panel and that the rear red light is functioning correctly.

3. Box spanner storage location

A 18mm box spanner used to replace the knives and to set the pressure of the hydro-pneumatic accumulators is supplied with the machine.

Place the box spanner (16) in its holder (17) (photo 11).

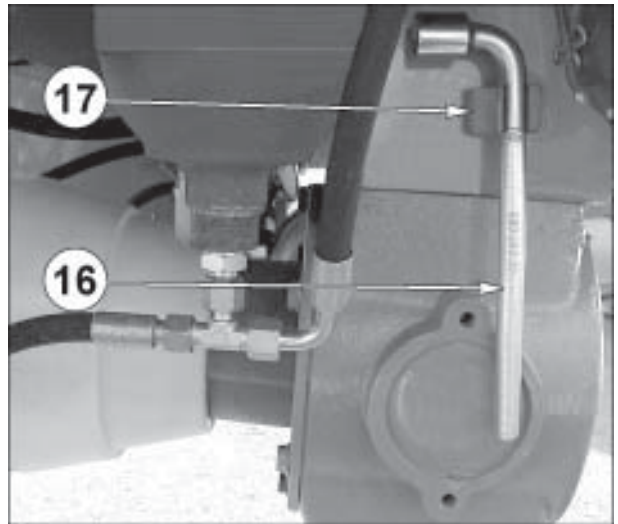

11

LOWER HITCH PIN ADJUSTMENT

The **GMD 802 - 902** are equipped with adjustable lower hitch pins which allow the multidisc mower to be offset 50 mm to the left and to the right to accommodate various tractor wheel track width (see page 17).

To adjust the lower hitch pins (18) (photo 15) proceed as follows :

- Loosen the 4 hexagonal screws (19) of clamping flanges (20) on each side.
- Slide hitch pins in new position respecting dimension 825mm (2'8 ") (see page 17).
- Retighten the hexagonal screws to 21 daNm / 150 ft.lbs.

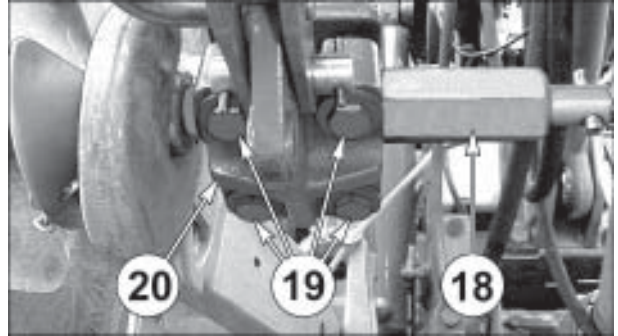

15



IMPORTANT

Check the torque of screws (19) after the first 10 hours of work following each lower hitch pin repositioning.

LOWER HITCH PIN ADJUSTMENT

Follow **fig. 1** for category 2 tractors with narrow wheel track.

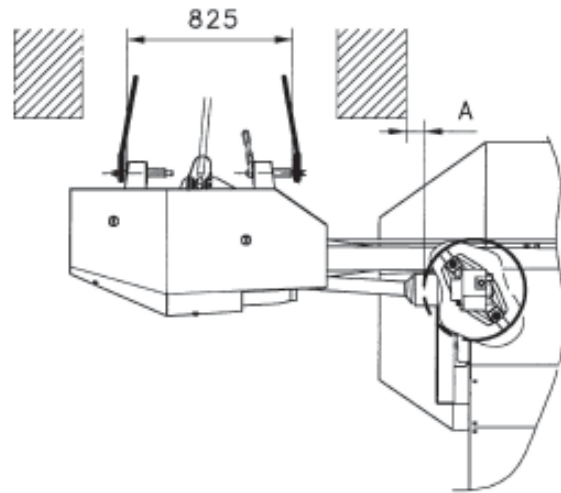

Fig. 1

Follow **fig. 2** for category 2 tractors with standard wheel track.

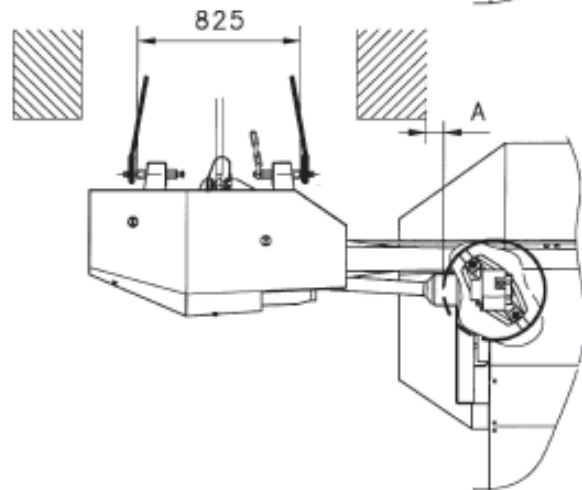

Fig. 2

Follow **fig. 3** for category 2 tractors with wide wheel track.

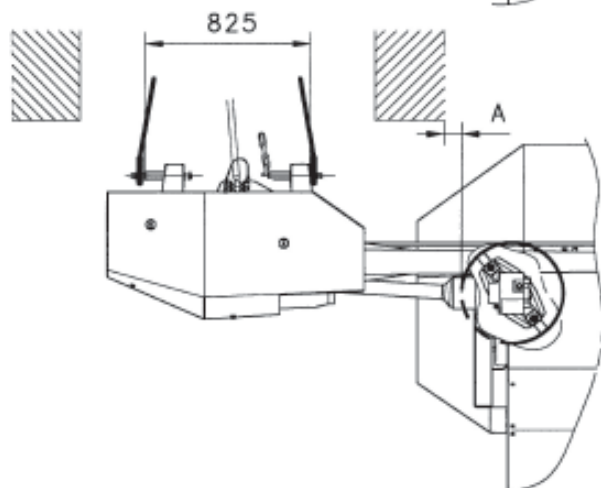

Fig. 3



Always attach machine in such a way that distance (A) is approximately 50 mm (2").

COUPLING TO THE TRACTOR

The **GMD 802 - 902** are coupled to the tractor with a category 2 headstock, a primary PTO shaft (1), a parking stand (2), a stop chain (4), 2 hydraulic hoses (3) and a 7 pin electrical plug (5) (photo 16).

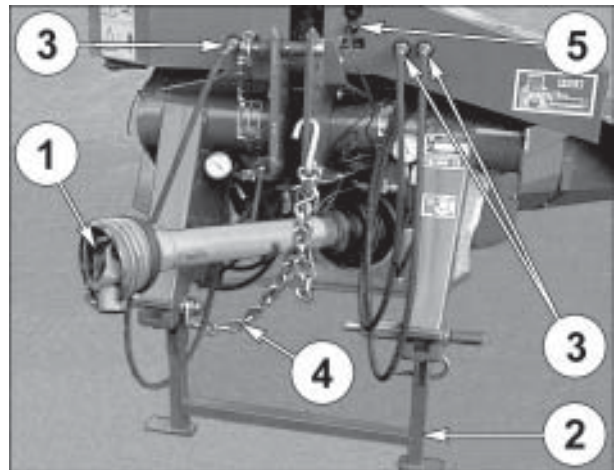

16

To obtain the maximum cutterbar ground clearance **in the raised position**, adjust the tractor levelling rods so that the draft links (7) are set 30-50 mm / 1"-2" below hitch pins (6) (photo 17) when the 3-point lift is fully lowered.

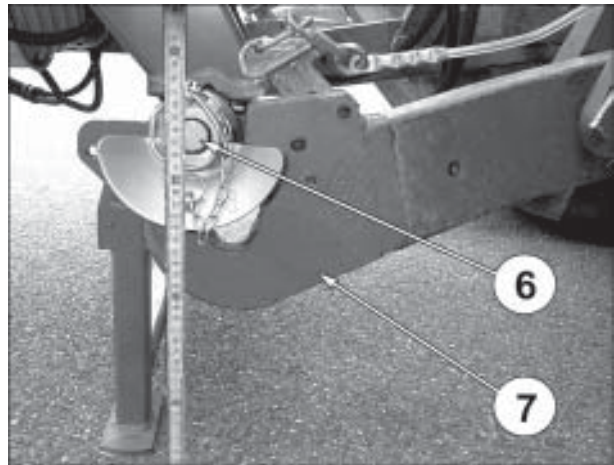

17

Attach draft arms (7) to hitch pins (6) and lower the machine on its parking stand (2) (photo 18).

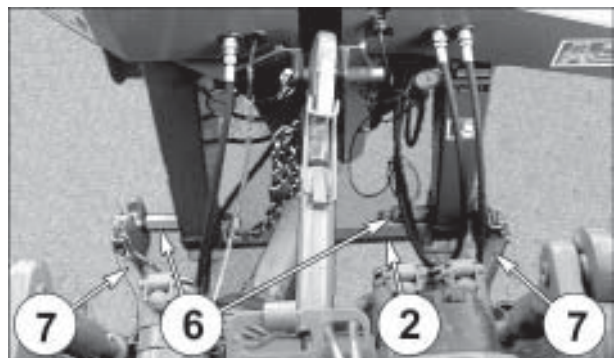

18



When attaching the top link (A) select one of the lower holes on the tractor side and one of the upper holes on the machine side in order to ensure a good ground clearance in transport position (drawing 4).

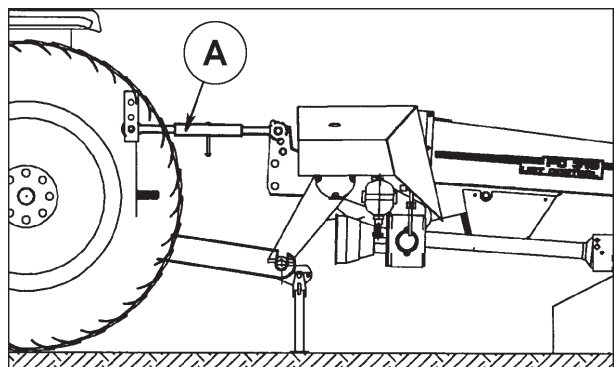

4

Connect hydraulic hoses (3) of the double acting cylinder used to set the machine from transport into working position and vice versa to a double acting valve (photo 19).

Connect hydraulic hose (8) of the lift cylinder to a single acting valve (photo 19). Connect the electric plug (5) (photo 19).

Fold the parking stand to the rear and lock in place. When these operations have been completed, activate the tractor 3 point lift to place the machine **in the raised position** (fig. 20 A) (see chapter WORKING POSITION on page 23).

The following situation may then be found (see photo 20) : since the machine is offset in relation to the tractor centre the combination of the right tyre crushing and the functional play of the 3 point lift pivot points may result in insufficient cutterbar ground clearance on its right end.

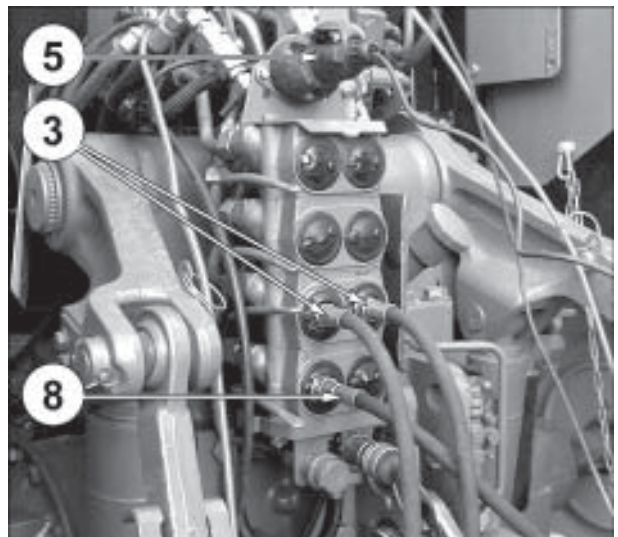

19



20

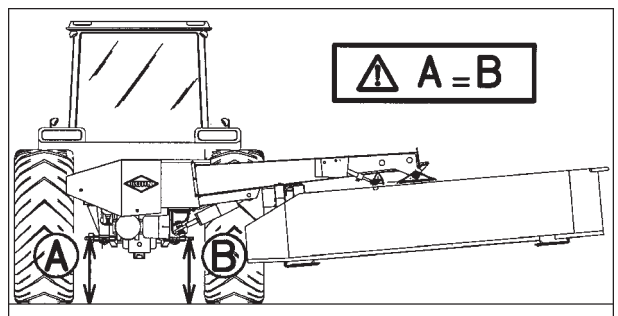

20A

If this problem is found proceed as follows :

- 1) Place the machine **in transport position** (see chapter TRANSPORT POSITION on page 24).
- 2) Lower the 3 point lift until the cutterbar rests on the ground.
- 3) Adjust the length of the left levelling rod (photo 21) so that the **hitch pins are parallel to the ground when the multidisc mower is in the « headland turn » position** (i.e. multidisc mower pivoted in the working position, 3 point lift raised).
- 4) Place the machine in the « headland turn » position and check that the **hitch pins are parallel to the ground** (fig. 20 A).
- 5) Repeat points 1 ; 2 ; 3 and 4 until a good cutterbar ground clearance is obtained.

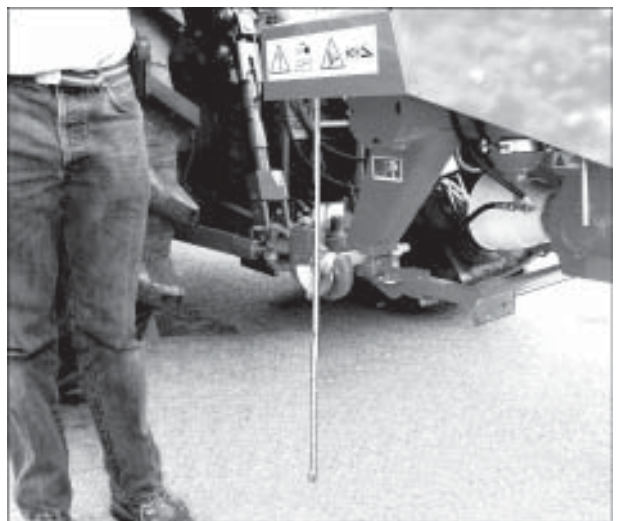

21

Note : A hitch pin (T) enabling direct attachment by means of a quick hitch (N) is supplied with machines intended for North America (photo 21 A). Mount the pin (T) on the 3-point frame using 2 roll pins (H) (diameter 10 x 45), as shown on photo 21 A.

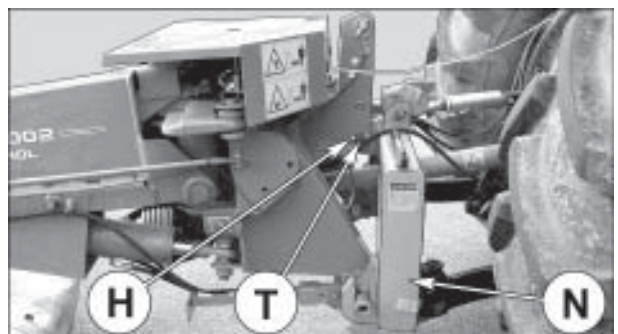

21A

ADJUSTMENT OF CHASSIS HEIGHT FROM THE GROUND

1. For tractors equipped with hydraulic position control function :

Set position control so that lower hitch pins are at a distance (H) of **600 mm (2')** from the ground (photo 22).

After having adjusted the chassis' height, move the stop against the 3-point lift control lever or set the position switch so that the 3-point lift lowers to the same depth each time.

In this case the stop chain delivered with the machine must not be used.

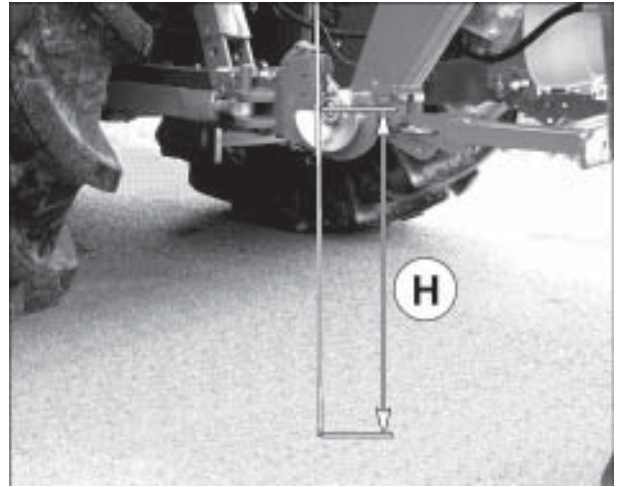

22

2. For tractors not equipped with hydraulic position control function :

In this case the stop-chain delivered with the machine must be used (photo 23).

Proceed as follows :

- Lower machine until hitch pins (1) are 600 mm (2') or slightly more from the ground.
- Connect stop-chain (2) with its hook supplied in the hardware kit of the machine to one of the free holes at the tractor's top link attachment clevis.
- Lower the machine into working position. Chassis height is correct when :

- The cutterbar is resting on the ground.
- Stop-chain (2) is tight.
- **H = 600 mm (2')** (distance of lower hitch pins from ground).
- The 2 hitch pins must be parallel to the ground.

- To keep this adjustment permanently, close hook eyelet (3) with roll pin (dia. 5 x 45 mm).

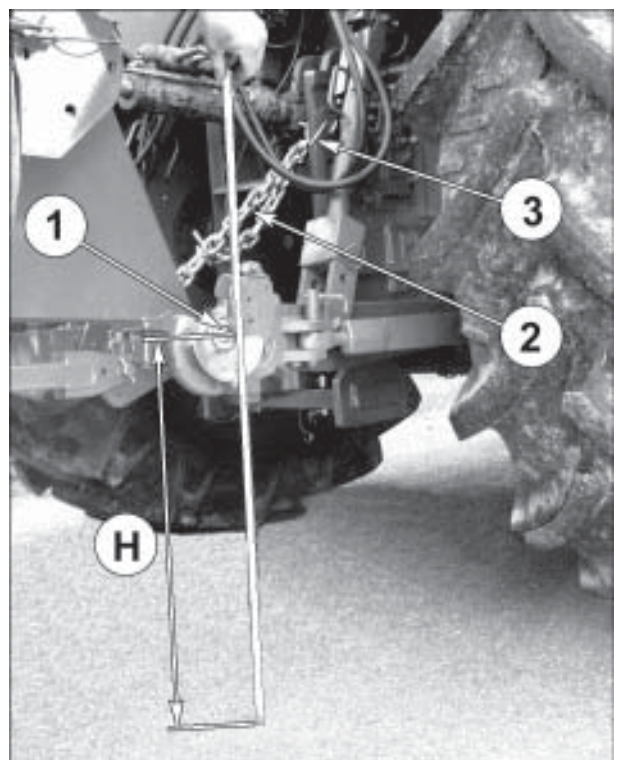

23

PRIMARY P.T.O. SHAFT

Connect the PTO shaft to the 1000 rpm (*min⁻¹*) PTO stub (see item 2, page 29).

Make sure PTO length is correct :

- 1) When the PTO is in its maximum extended position, a minimum tube overlap of 250 mm (10") must be maintained.
- 2) When the PTO is in its maximum overlap position (retracted), tubes should not butt against the yokes. As a safety measure a clearance of at least 10 mm (2/5") must be maintained (fig. 24). If this is not the case, shorten the two transmission tubes and the two guard tubes by the same length (fig. 25 and 26). Bevel and clean the tubes (fig. 27) and grease the inside of the outer tube (fig. 28).
- 3) Never operate the PTO at too great an angle ($X = \pm 30^\circ$ maximum) (fig. 28A).

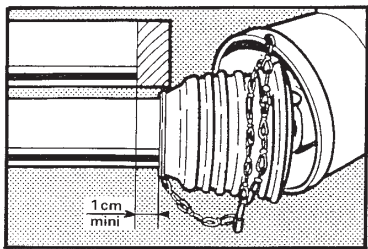

24

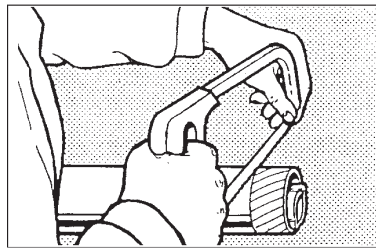

25

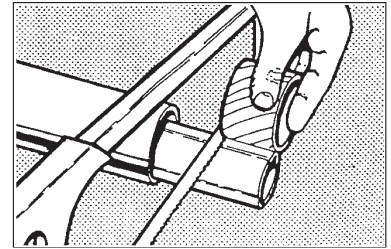

26

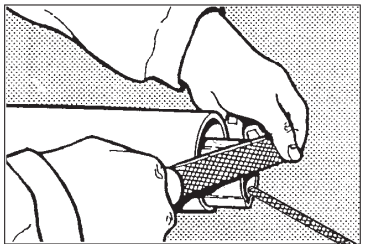

27

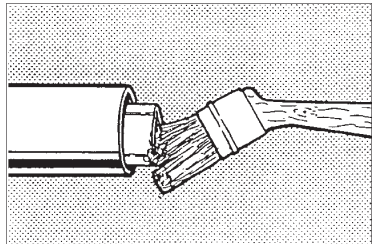

28

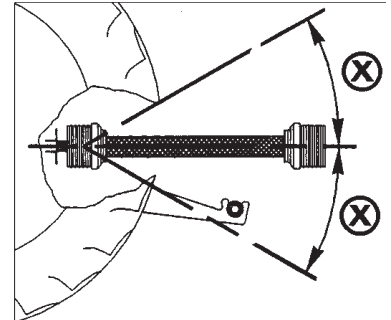

28A



These recommendations and adjustments must be respected to avoid damage or premature wear of the PTO.



DANGER

To avoid accidents which could be serious, make sure that the guards are always correctly in place and secured with the safety chains. On the machine side attach the PTO shaft guard chain (1) to the hole of the top link yoke (photo 29). Worn or damaged guards must be replaced immediately.

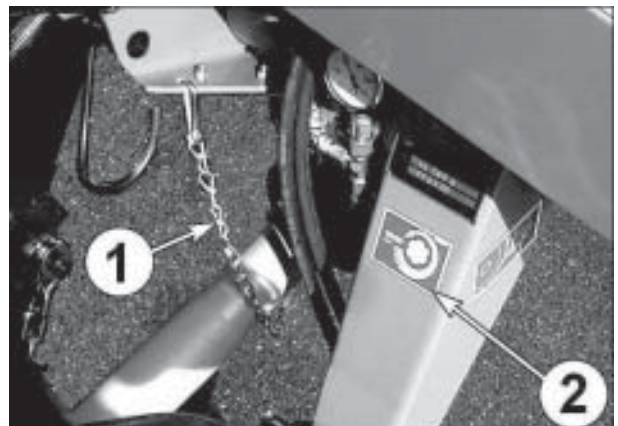

29

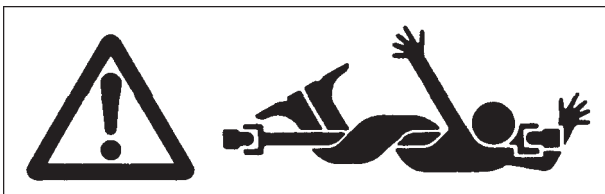

SECONDARY P.T.O. SHAFT



DANGER

Before carrying out any operation such as maintenance or adjustment on the machine, stop the tractor engine, remove ignition key and wait for rotating discs to stop.

The machine's secondary PTO shaft is fitted with a friction slip clutch.



ATTENTION

Before the machine is put into service and after a long period of non-use, check the function of the slip clutch to ensure it is not locked up.

- Remove the secondary PTO shaft from the gearbox (see photo 29A).



29A

- Tighten the peripheral hexagonal nuts several turns evenly until the discs are released (figure A). Rotate the torque limiter's hub a few turns to make sure the discs are not seized by rust or foreign material build up.

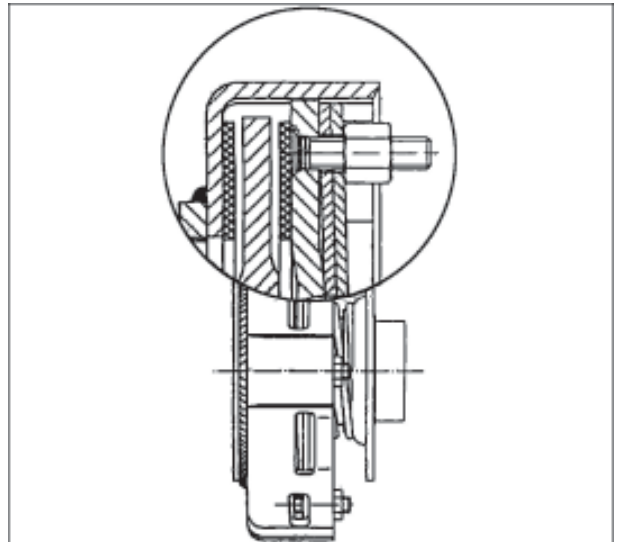

A

- Thread the hexagonal nuts away from the pressure plate until they bottom against the end of the threaded studs (figure B). The nuts must not contact the pressure plates in work or damage will result to the slip clutch.

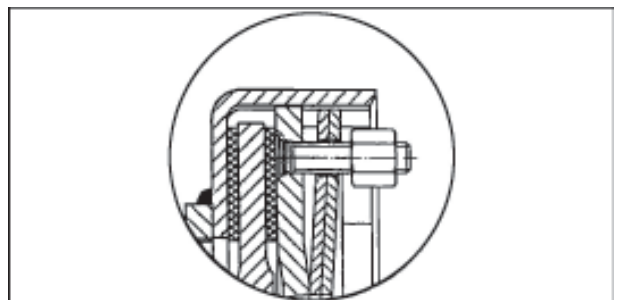

B

WORKING POSITION



DANGER

Warning : Before putting the machine in the working position ensure that the pivoting front protector has been lowered and that all persons are well clear of the cutterbar pivoting area.

To put the machine in the working position, proceed as follows :

- Lift the machine from the ground.
- Fold the parking stand to the rear and lock in place (photo 30).
- Pull the cord (1) tightly to free the stop pin (photo 30), maintain the tension on the cord (1).
- Activate the hydraulic cylinder to bring the cutting head into the working position. (If the tractor is fitted with an oil flow limiter, adjust it so that the pivoting speed is limited). Locking in the working position is automatic.

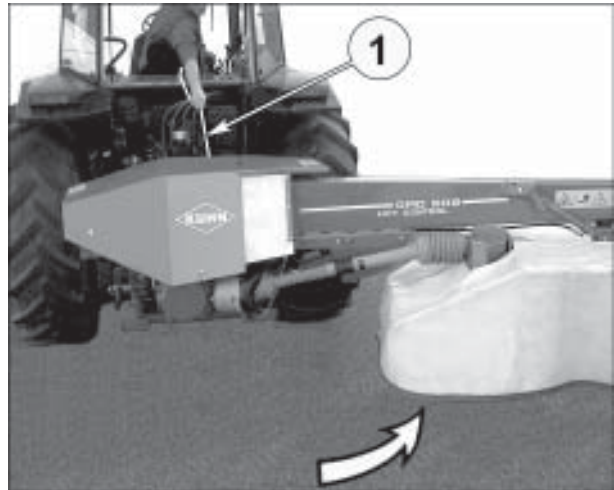

30

- Using the tractor's lift linkage, lower the machine in "headland turn" position (photo 31), [H=600 mm / 2' (photo 22, page 20)].



IMPORTANT

To lift the machine in "headland turn" position, do not use the tractor's lift linkage, only use the single acting cylinder located under the frame.



31

- Lower the mowing unit on the ground using the single acting cylinder and **leave this cylinder in free floating position.**



31A

TRANSPORT POSITION



DANGER

Attention : Before pivoting the cutting head into the transport position, wait until the rotating discs have come to a complete stop and ensure that there is nobody in the cutting head pivoting area.



ATTENTION

Do not pivot the cutting head into transport position if the torque limiter has become very hot due to slippage. Allow it to cool down to normal temperature first.



ATTENTION

Before transporting the machine on the public highway, the operator should make sure that the machine conforms to the highway code.

To transport the machine on public roads or from one field to another, proceed as follows :

- Make sure discs have come to a complete stop.
- Lift the machine using the tractor 3-point linkage
- Lift the mowing unit using the single acting lift cylinder.
- Pull cord (1) tightly to free the stop pin (photo 32). Maintain the tension on the cord (1).
- Pivot the cutting head by activating the machine's hydraulic cylinder. Locking into the transport position is carried out automatically.
- Release the strain on the cord (1).
- Before driving onto a main road, ensure that the upper edge of the signalling panel (2) is not more than 1.5 m / 5' from the ground (photo 33).

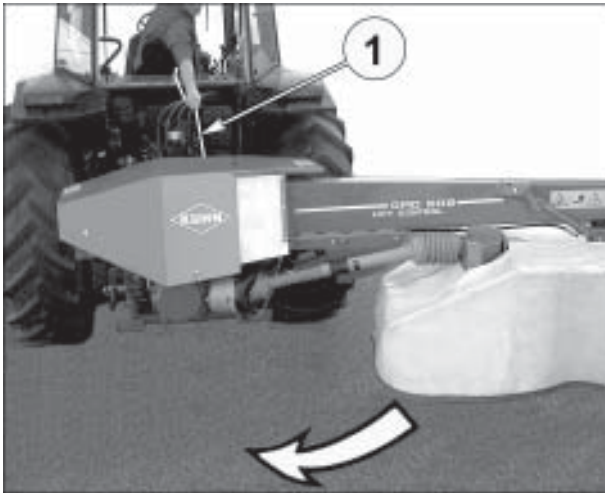

32



33



ATTENTION

Ensure that decal (2) (ref. 099 166 00) (photo 33) on the signalling panel is replaced as soon as it is worn or damaged.

ADJUSTMENTS

1. CUTTING HEIGHT

Maximum cutting height (80 mm / 3 1/5") (fig. 6) is achieved when the discs are parallel to the ground. Adjustment of cutting height is achieved by altering the cutterbar tilt angle. This is effected by varying top link length (1) (photo 34) until desired cutting height is obtained. This manoeuvre is facilitated by folding the machine in transport position and placing it on its parking stand in order to reduce loading on the top link (1) (photo 34). To minimize blade and disc wear, improve grass regrowth and get maximum nutritive value from the crop, minimum cutting height should never be adjusted less than 30 mm / 1 1/4" (fig. 7).

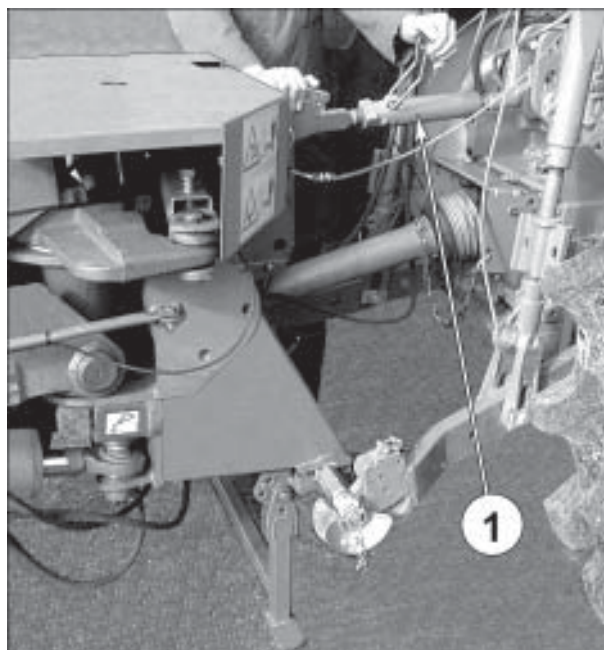

34

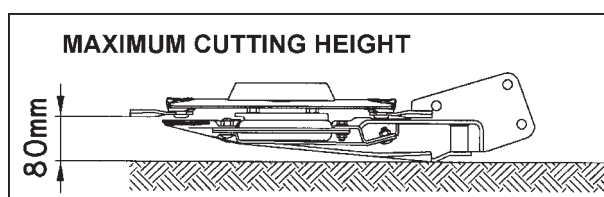

6

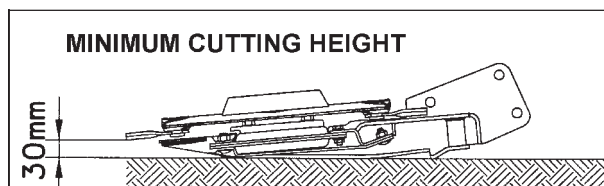

7

2. SWATH WHEELS

The position of the **outer swath wheel (GMD 802 - 902)** and **inner swath wheel (GMD 802 only)** must be adjusted so that the security distances "X" and "Y" are respected compared to the disc extremities :

- for the outer swath wheel

X = 17 to 25 mm / 0.66" to 1"

Y = 17 to 25 mm / 0.66" to 1"

- for the inner swath wheel

X = 17 to 25 mm / 0.66" to 1"

Y = 17 to 25 mm / 0.66" to 1"

For the inner swath wheel the distance "X" corresponds to the space between the swath wheel and the gussets (N) on the inner disc cone.

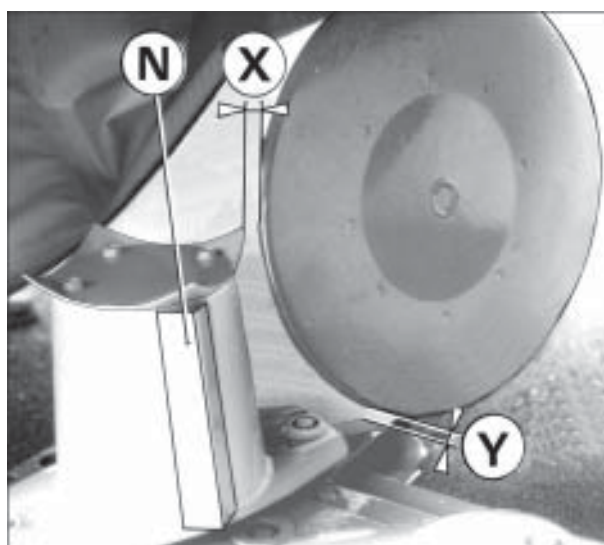

35

3. ADJUSTING THE PRESSURE ON THE GROUND AND THE SAFETY BREAKBACK

The cutting unit ground pressure is controlled by a hydro-pneumatic accumulator. Increasing the pressure in the accumulator decreases the cutting unit ground pressure and vice versa.

The hydro-pneumatic accumulator also operates the lift control function of the multidisc cutting unit. If the resistance against forward motion increases (uneven ground ; hitting an obstacle) the cutting head pivots to the rear which in turn increases the accumulator pressure and decreases the cutting unit ground pressure. The cutting unit is thus lifted over the obstacle, then regains its position automatically.

In case a major obstacle is struck, the cutting unit can pivot up to 25° to the rear (in such a case check that no cutterbar component has become damaged).

The accumulator pressure must be set with the machine in working position and with the lower hitch pins being set at the correct distance of 600 mm from the ground (H = 600 mm, see page 20).

Check the pressure given on the gauge (6) (photo 36).

	GMD 802	GMD 902
NORMAL operating pressure	85 bars / 1232 psi	95 bars / 1377 psi
MINIMUM operating pressure	75 bars / 1087 psi	85 bars / 1232 psi
MAXIMUM operating pressure	100 bars / 1450 psi	110 bars / 1595 psi

NEVER OPERATE THE MACHINE WITH AN ACCUMULATOR PRESSURE NOT COMPRISED WITHIN THESE LIMIT VALUES

The hydro-pneumatic suspension accumulator is pressurised by means of the tractor's hydraulic circuit.

To **increase pressure** proceed as follows :

- open the valve (4) on the hydraulic bloc (5) with the box spanner supplied with the machine (photo 36),
- start-up the tractor,
- **SLOWLY** increase pressure, checking indication of the gauge (6), the tractor valve control lever or switch being shifted in the "pivoting into work" position,
- once the required pressure has been obtained shift the tractor valve to neutral and close valve (4).



36

To **reduce the pressure**, proceed as follows :

- turn off the tractor motor,
- open valve (4) on the hydraulic block (5),
- **SLOWLY** reduce pressure, checking the indication of gauge (6), the tractor hydraulic control lever or switch being shifted in the "pivoting into transport" position,
- once the required pressure has been obtained shift the tractor valve to neutral and close valve (4).

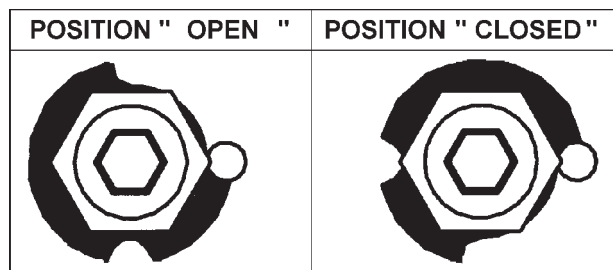

DANGER

Never use the valve (4) for any other reason that those mentioned above.

4. ADJUSTMENT OF THE MOWING UNIT STABILISING PRESSURE

The GMD 802 - 902 are equipped with a 2nd hydro-pneumatic stabiliser accumulator which enables adjusting the mower stabilising pressure in **“headland turn” position and in TRANSPORT POSITION**. The mowing unit stabilising pressure is increased or decreased by modifying the accumulator pressure.

Check the pressure given on the gauge (6A) (photo 37).

	GMD 802	GMD 902
NORMAL operating pressure	160 bars / 2320 psi	110 bars / 1595 psi (*)
MINIMUM operating pressure	160 bars / 2320 psi	110 bars / 1595 psi (*)
MAXIMUM operating pressure	170 bars / 2465 psi	120 bars / 1740 psi (*)

NEVER OPERATE THE MACHINE WITH AN ACCUMULATOR PRESSURE NOT COMPRISED WITHIN THESE LIMIT VALUES.

(*) the GMD902 incorporates a higher capacity stabilising cylinder hence the lower stabilising pressure.

The hydro-pneumatic stabiliser accumulator is pressurised by means of the tractor's hydraulic circuit.

To **increase pressure** proceed as follows :

- open the valve (4A) on the hydraulic bloc (5A) with the box spanner supplied with the machine (photo 37),
- start-up the tractor,
- SLOWLY increase pressure, checking indication of the gauge (6A), the tractor valve control lever or switch being shifted into the **“headland turn”** position,
- once the required pressure has been obtained shift the tractor valve to neutral and close valve (4A) (photo 37).



37

To **reduce the pressure**, proceed as follows :

- turn off the tractor motor,
- open valve (4A) on the hydraulic block (5A) (photo 37),
- SLOWLY reduce pressure, checking the indication of gauge (6A), by activating the tractor hydraulics in the same way as when lowering the mowing unit on the ground with its single acting cylinder,
- once the required pressure has been obtained shift the tractor valve to neutral and close valve (4A) (photo 37).

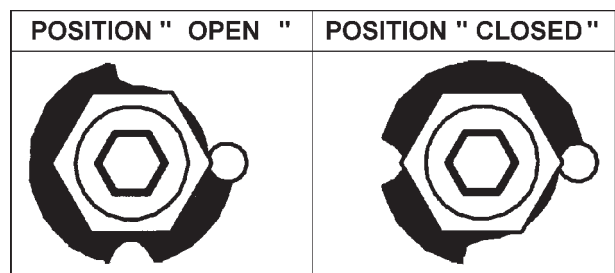

DANGER

Never use the valve (4A) for any other reason that those mentioned above.

PARKING THE MACHINE



DANGER

For your safety, always park the machine with the cutting head in the “transport” position.

To park the machine, proceed as follows :

- Ensure that the cutting head is in the transport position.
- Disconnect the stop chain (1) if this accessory is used for setting the height of the chassis from the ground (photo 38).
- Lower and lock the parking stand (2) (photo 38).

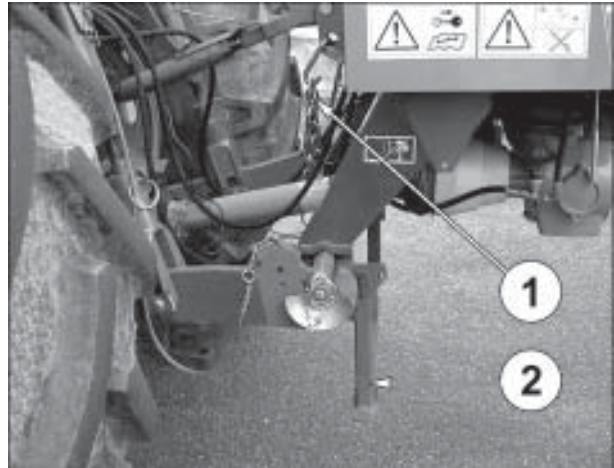

38

- **Lower the mowing unit** only using the single acting cylinder (3) (photo 39). Leave the valve in float detent.
- Lower the tractor lift linkage so that the machine rests on its parking stand (2).



39

- Uncouple the PTO shaft (4) and place it in support (5) (photo 40).
- Disconnect the electric plug (9) as well as the male couplers (6) and place them in their respective supports (photo 40).
- Disconnect the top link from the 3-point frame (7) (photo 40).

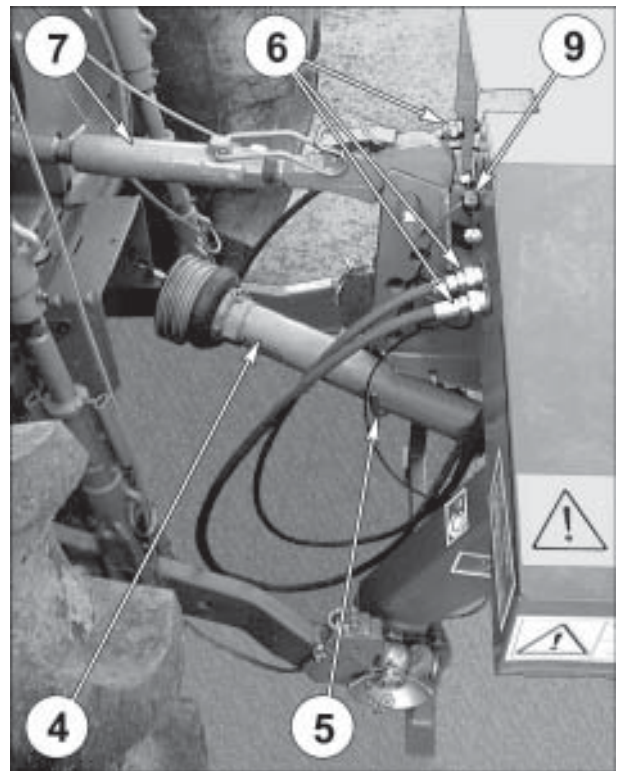

40

- Uncouple the lower tractor draft arms (8) (photo 41).
- Now the machine is parked (photo 42).

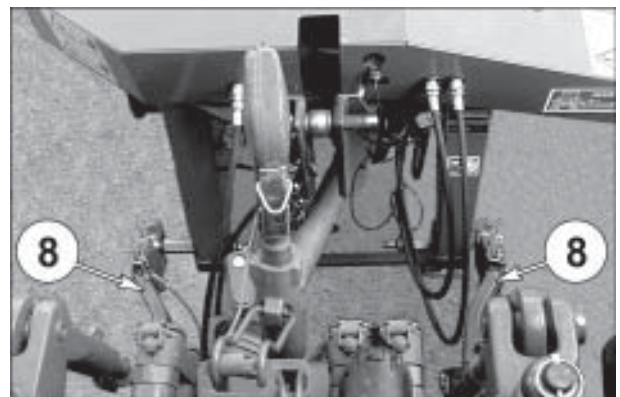

41

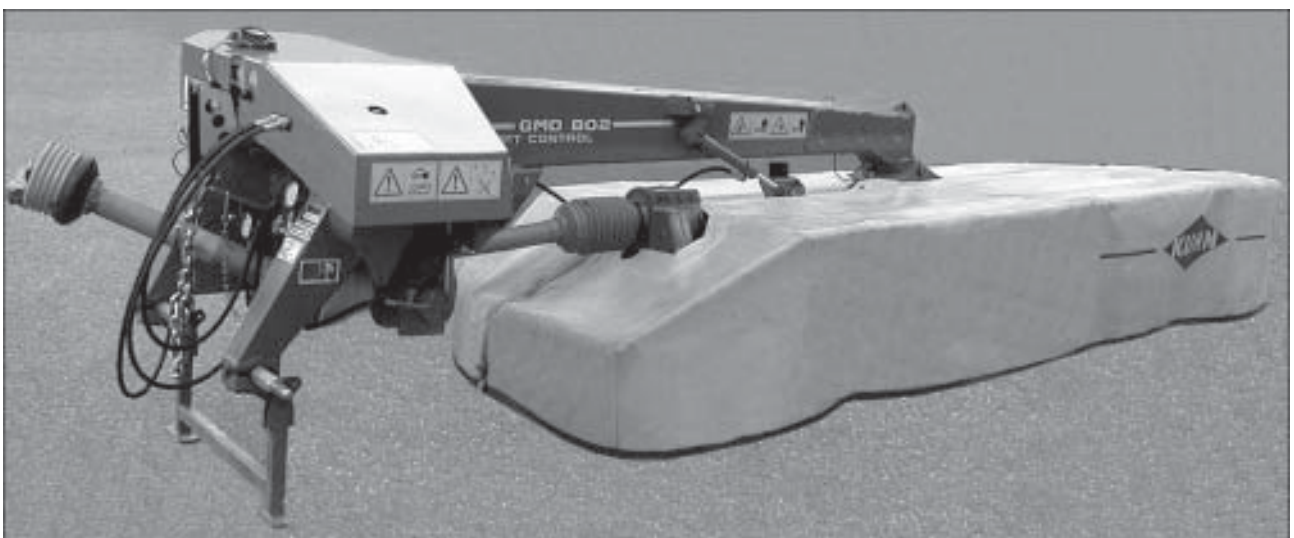

42

OPERATING THE MULTIDISC MOWER



DANGER

Adjust machine to clear obstructions and debris.

Foreign objects and other debris can be deflected toward the operator and bystanders.



DANGER

Attention, before placing the cutting head into the working position, release the lock (1) and lower the protection cover (2) in work position (see arrows in photo 43). Ensure that the safety curtain is completely in place around the cutting unit.

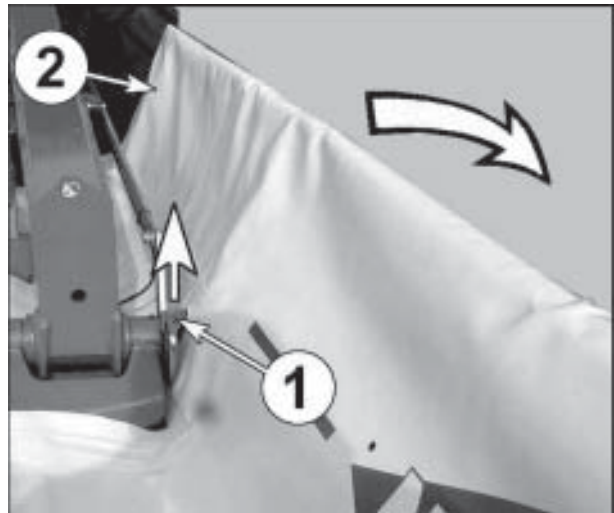

43



DANGER

Never mow in stony or rocky grounds.



ATTENTION

Never operate the mower without the protection cover in place. Do not lean against or stand on the guard cover.

Before cutting, engage tractor PTO and slowly increase the speed (*rotational frequency*) up to 1000 rpm (min^{-1}).

Forward speed must be adapted to working conditions and should be reduced when mowing dense crops.

MAINTENANCE



DANGER

Before carrying out any operation such as maintenance or adjustment on the machine, stop the tractor engine, remove ignition key and wait for rotating discs to stop before leaving the tractor.

Any intervention (changing the knives, grease, lubrication etc ...) must be done with the machine in the transport position, except when greasing the secondary PTO transmission shaft.

HYDRO-PNEUMATIC ACCUMULATORS

The hydro-pneumatic accumulators (1) (photo 44) require no special maintenance, but like all pressurised containers, it is **strictly forbidden to weld, grind or drill onto them.**

- Regularly check that the fixing bolts of the supports are tight.
- Regularly check that no oil has leaked from the hydraulic circuit (a small oil leak can, with time, change the characteristics of your setting).



DANGER

Before any intervention to a circuit with accumulator, ensure that the circuit is released from oil pressure.

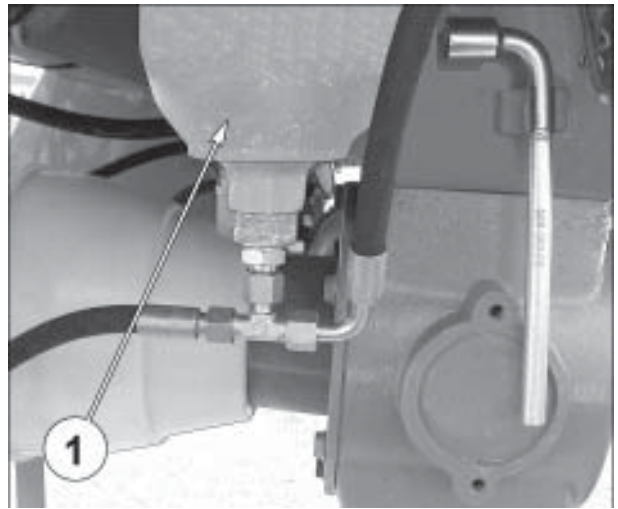

44

To do this, proceed as follows :

- Place the cutting unit in working position.
- Switch the tractor motor off, remove the ignition key and wait for rotating discs to stop.
- Open the valves (4, 4A) on the hydraulic blocs (5, 5A) (photos 45 and 46).
- Release the pressure completely. Check that the needle on the gauges (6, 6A) reads "0 bar".
- Close the valves (4, 4A).



45



46



DANGER

Repressurise the accumulators before actuating any hydraulically controlled function.



ATTENTION

The pressure in the hydro-pneumatic accumulators must be controlled every 10 years by an authorised organisation.

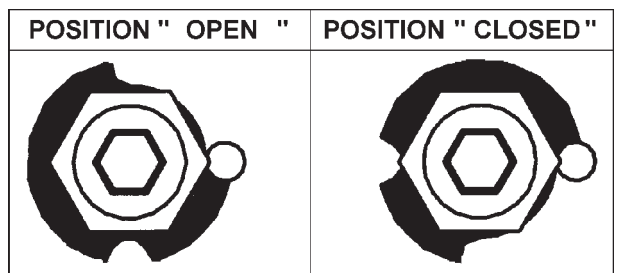

BASIC ADJUSTMENTS :



Before any intervention on the machine, make sure to depressurise the circuit, then open a fitting to release any residual hydraulic pressure.

1) Drive (fig. 47)

Following all interventions on the drive system check, when reassembling, that the distance between the side gearbox drive shaft axis and the upper side of the cutterbar stiffener equals measure $A = 577 \pm 4$ mm.

2) Compensating cylinder (1) (fig. 48)

Basic length in retracted position : 775 mm / 2' 6.5".

3) Transport/work cylinder (2) (fig. 48)

In working position (cylinder retracted), bring the connecting arm (3) in contact with the frame stop (6). Adapt the length (X) of the cylinder (2) in such a way as to obtain a play of 2 to 4 mm between lever (4) and the stop (7) of the chassis.

4) Transport stop (5) (fig. 48 and photo 49)

After placing the machine in transport position (cylinder extended), bring the stop (5) in contact with the damper (7) (photo 49) and give it two preload turns.

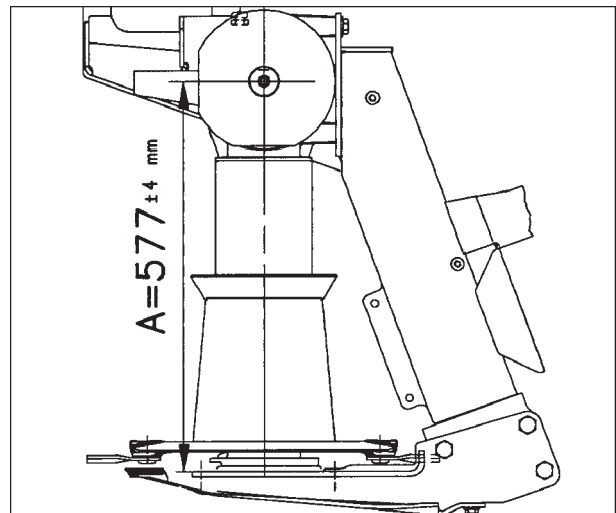

47

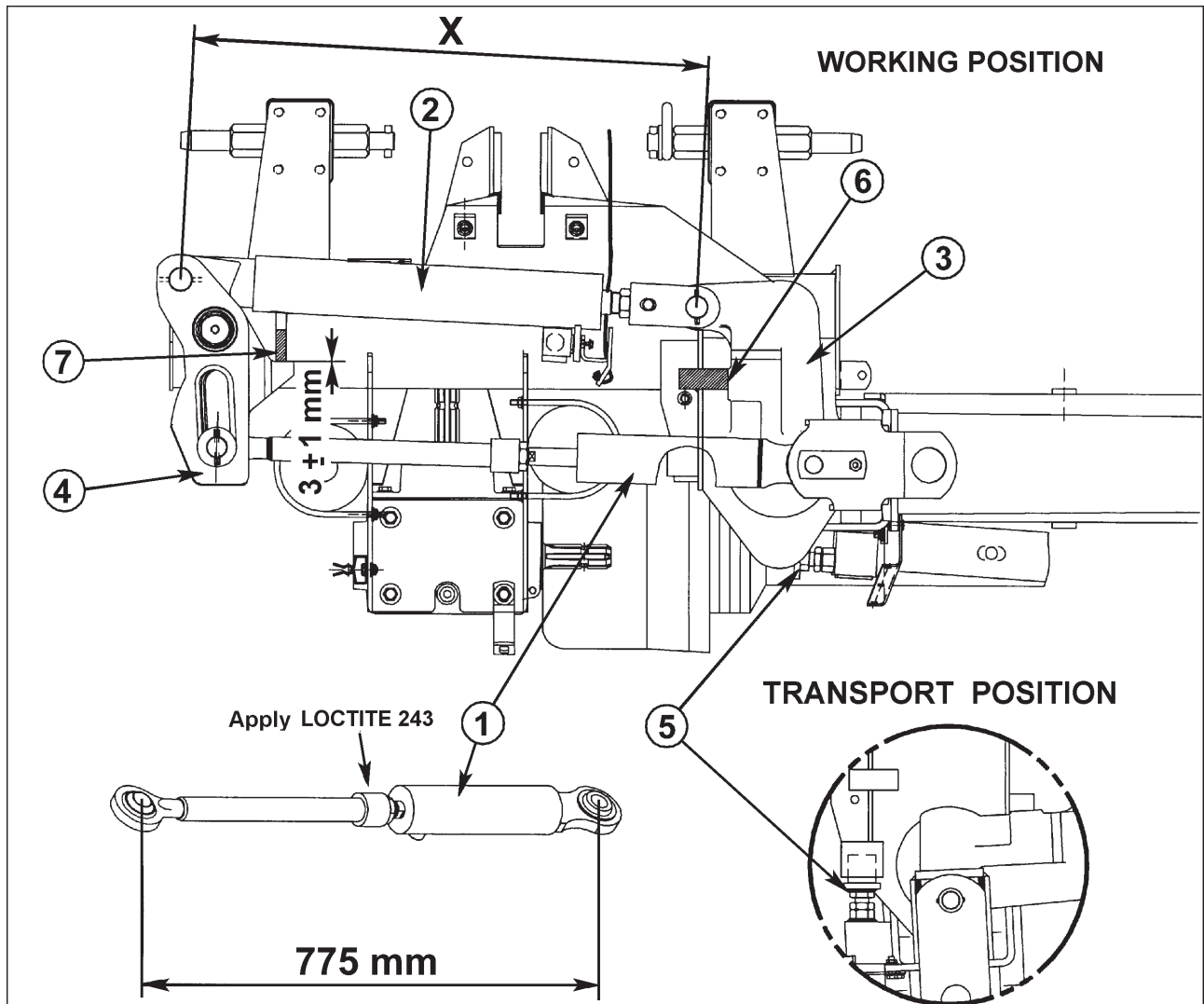

48

TRANSPORT STOPPER :

Transport stopper (5) limits the side way of the multidisc mower. If this movement is too big lengthen stopper (5) to eliminate play. Adjustment must be made while the machine is in transport position (cylinder completely extended). Do not forget to tighten the counter nut (6) after adjustment.

The rubber stop (7) (code n° 568 645 00) must be replaced when it has been worn down (flattened) and has lost its function as a shock absorber (photo 49).

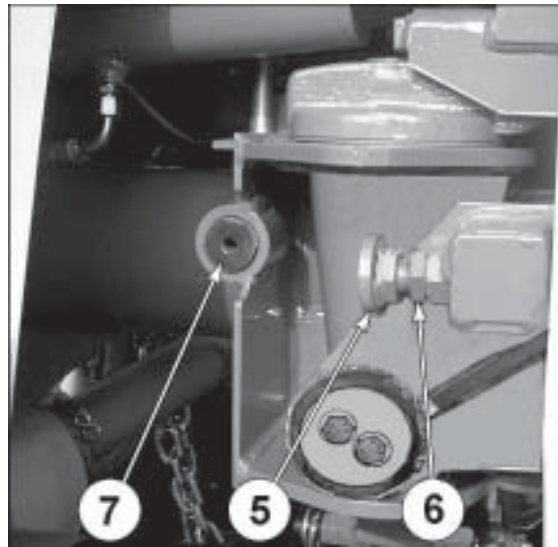

49

ACCESS TO CUTTERBAR



DANGER

Before carrying out any operation such as maintenance or adjustment on the machine, stop the tractor engine, remove ignition key and wait for rotating discs to stop before leaving the tractor.

Any intervention (changing the knives, grease, lubrication etc ...) must be done with the machine in the transport position, except when greasing the secondary PTO transmission shaft.

Access to the gearcase is easier once the protector cover (A) has been raised (photo 50)

Proceed as follows:

- Place the machine into the TRANSPORT position.
- Gently lift up the canvas using the strap (P) (photo 50).
- Fold the protector upwards and lock it with the latch (V) (photo 50).
- After the intervention, replace the protector cover.

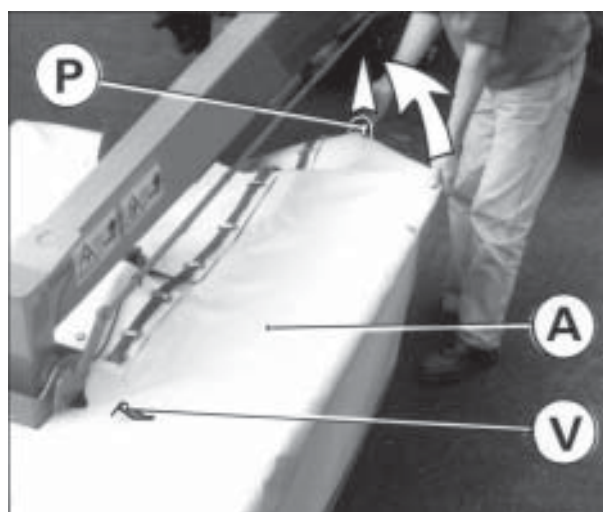

50

1. INSPECTION OF KNIVES AND SECURING ELEMENTS

Discs, knives and securing elements are manufactured from high quality steel and have been subjected to a heat-treatment to assure a high resistance to wear.

Worn or damaged items must immediately be replaced with genuine KUHN parts as otherwise warranty will be withdrawn.

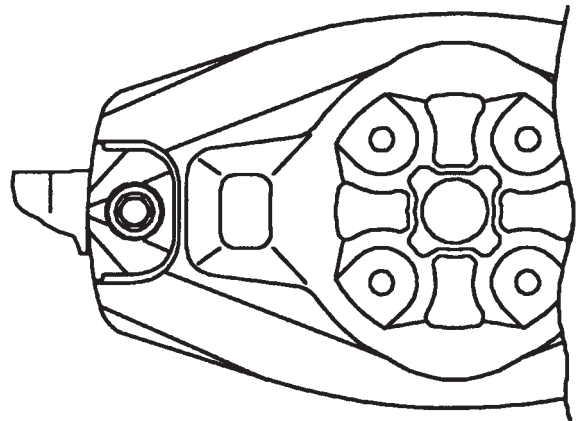

A) KNIVES : should be inspected systematically each time before the machine is operated.

Cutting quality as well as safe operation depend on the regular inspection and care given to the knives. Knives should be replaced in the following cases :

a) Damaged knives

Very rough conditions can cause knives to crack and become deformed leading to :

- increased risk of accidents ;
- deterioration of cutting quality ;
- risk of damage to the cutterbar.

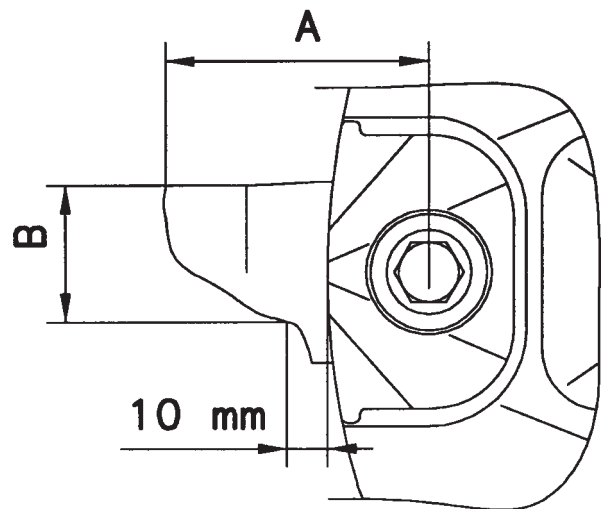

b) Worn knives

Length (A) of a knife should be greater than 65 mm. The width (B) of a knife, measured at a distance of 10 mm away from the edge of the disc should be greater than 34 mm.

The hole (L) for the securing bolt must not become oval by more than 20 mm for an 18 mm hole.

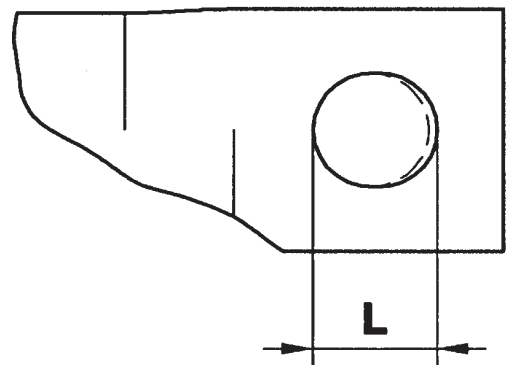

B) SECURING ELEMENTS : To be inspected regularly !

(particularly the tightening torque of the nut:
12 daNm / 90 ft.lbs).

- Inspect immediately after hitting an obstruction.
- Inspect when replacing knives.
- Check at the beginning of each season.

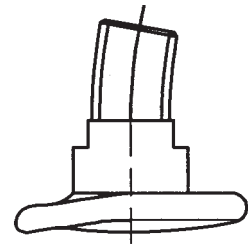

a) The securing bolt must be replaced :

- When a visible deformation is found.
- When the locking compound on the threads has worn away or if the locking compound has become inoperational due to inclusion of water, oil or dirt.

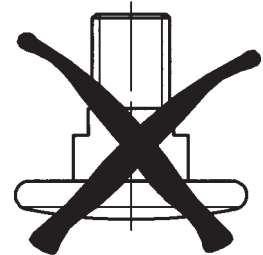
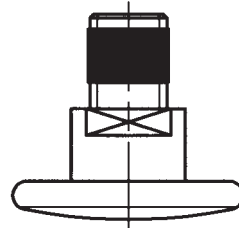

- When wear on the head reaches the contact area of the knife.

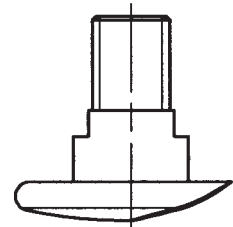

- When the diameter (**D**) of the bolt shoulder is less than 15 mm (5/8 ").

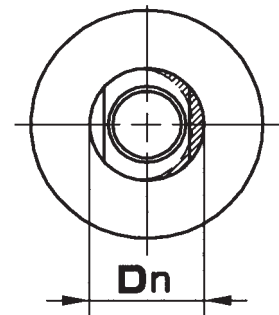
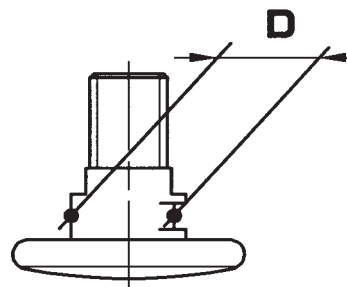

b) The nuts must be replaced :

- When the contact washer has lost its elasticity or when it becomes loose from the nut.



- When wear on the nut reaches $a = 5$ mm.

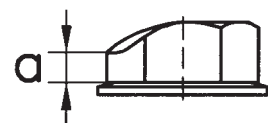

DANGER

For the correct operation of your machine, always use genuine spare parts.

Regularly check all nuts and bolts for correct tightness, particularly those securing discs and blades.

2. KNIFE REPLACEMENT

To replace knives, first clean the area around nut (A) (photo 51) and remove nut with the box spanner (T) supplied with the machine. To facilitate the removal of the nut, we recommend to place a block of wood (Z) between 2 discs to stop them from rotating (photo 51). Remove the bolt (W) through the hole located at the front of the disc guard (photo 52).

Ensure securing elements are in good condition and fit knives so that the arrow on their upper face is pointing in the direction of rotation of the corresponding disc (fig. 53).

Torque locknut to 12 daNm / 90 ft.lbs.

Important : Always replace securing elements (lock-nuts and bolts) when they have been removed 5 times.

Caution : Always replace damaged knives, never straighten a bent knife.

Never replace one knife only per disc, always replace both of them to avoid creating an out-of-balance force.

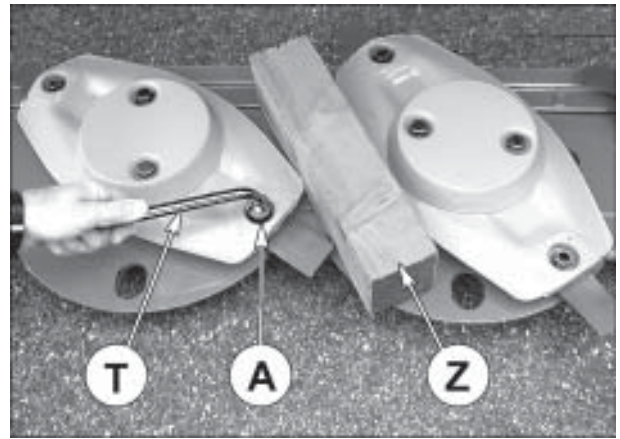

51



52

GMD 802

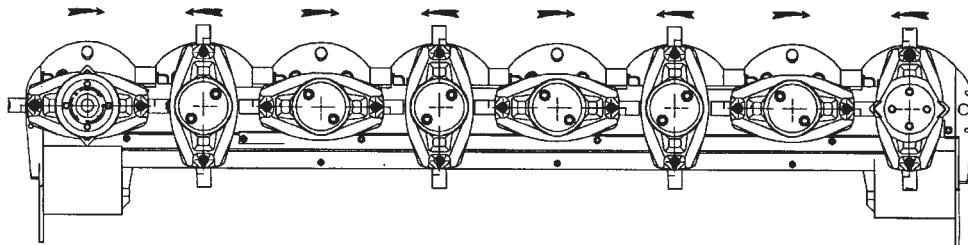
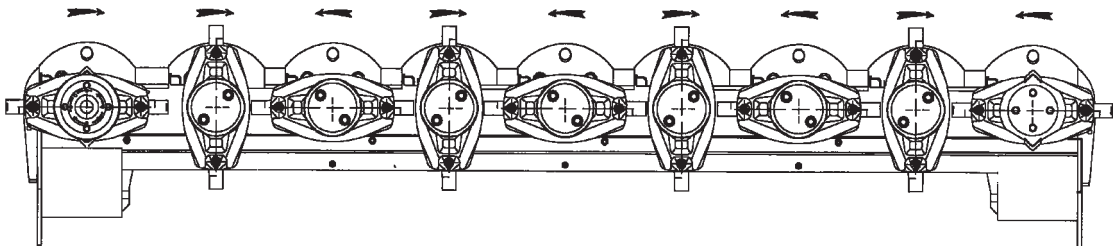

Fig. 53

GMD 902



Dull knives require more horse power to cut the crop and will leave an uneven stubble.

Worn knives should either be turned over on the same disc to use the other cutting edge, or replaced. When turning or replacing the knives, make sure there is a 1 mm minimum gap between the knives or their mounting bolts and the cutterbar wear plates. If otherwise, insert one (**maximum two**) distance spacer(s) (code 568 071 00) between the discs and the disc bearing stations (fig. 54).

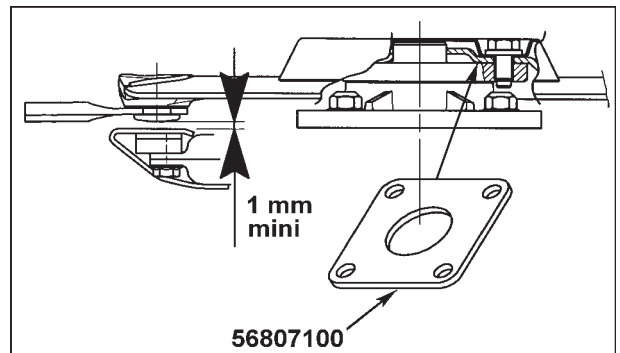

54

3. DISCS REPLACEMENT

To replace a disc, place a block of wood (Z) between two discs to stop them from rotating. Unscrew the 4 nipple-screws (B) with the box spanner (T) supplied with the machine and take the 4 conical spring washers (C) off (photo 55 and fig. 56).

Two of these diametrically opposite bolts are also used to secure the conical covers on top of the discs (fig. 56). When remounting must the discs have their largest diameters positioned at right angles to each other. This positioning must be scrupulously respected so as to avoid interference between the knives (see photo 52). Take extra care when fitting the conical spring washers (C) (fig. 56), which must be positioned with the conical centre at the top.

Tighten bolts to a torque of 12 daNm (90 ft.lbs).



IMPORTANT

Discs supplied through our spare parts department come with a 1 mm spacer (part no. 568 071 00) (fig. 54) attached to them. When installing a new disc check if the gap between the blades or their mounting bolts and the cutterbar protection shields is at least 1 mm. If this is not the case fit the 1 mm spacer between the disc and its mounting hub for increased clearance (fig. 54).

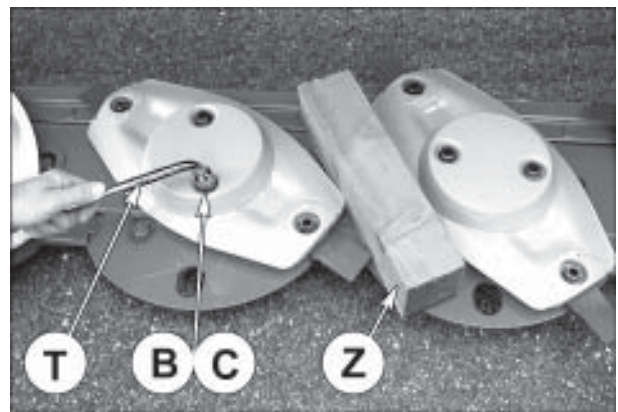

55

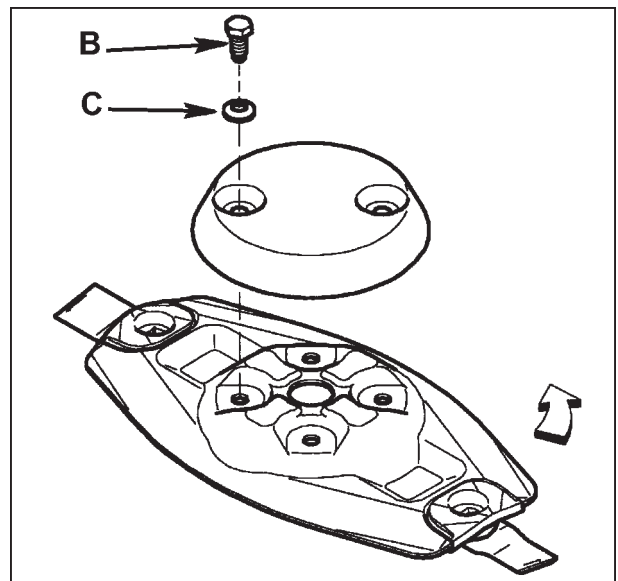

56

Make sure cone lids (1 - 2) are properly secured in place (photos 57 and 58). Tightening torque of bolts (V) is **8 daNm (60 ft.lbs)**. Replace immediately a loosen or damaged cone lid.

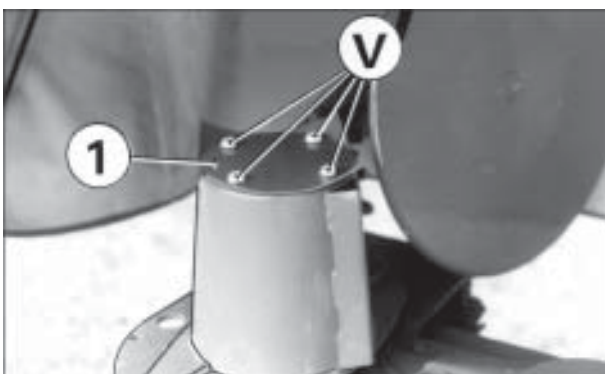

57

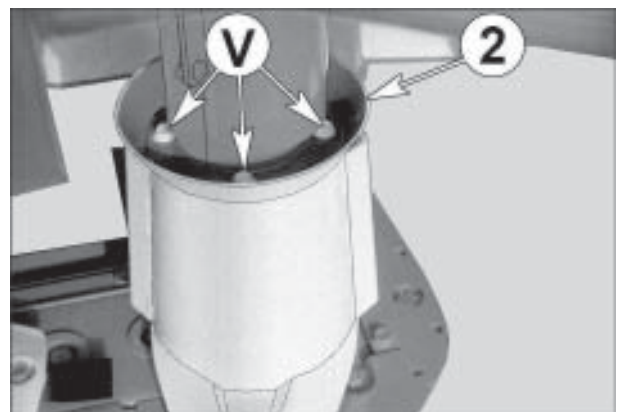

58

LUBRICATION

It is forbidden to discard oil, grease or filters of any type. These must be given to specialised waste disposal organisations to protect the environment.



DANGER

Before any intervention on the machine (maintenance or adjustments), place the machine into the transport position, switch off the tractor's motor, take the key out of the ignition and wait until all moving parts have come to a halt.

	GMD 802	GMD 902
Quantity of oil in central gearbox [Quality SAE 80 W EP (GL4)]	2.3 litres 4 Imp. pints - 4.6 US pints	2.3 litres 4 Imp. pints - 4.6 US pints
Quantity of oil in cutterbar [Quality SAE 80 W EP (GL4)]	2.25 litres 4 Imp. pints - 4.5 US pints	2.5 Litres 4.3 Imp. Pints - 5 US Pints
Quantity of oil in lateral gearbox [Quality SAE 80 W EP (GL4)]	0,9 litre 1.6 Imp. pints - 1.8 US pints	0,9 litre 1.6 Imp. pints - 1.8 US pints

NOTE : Before draining oil, operate the cutterbar for a few minutes so that oil warms up.

IMPORTANT !

Imperatively change oil in cutterbar **after the first 10 hours of use [SAE 80 W EP (GL4)].**

Thereafter, oil must be changed every 200 hours of work and at least once per year in :

- cutterbar
- cutterbar lateral gearbox
- central gearbox.

CHANGING THE OIL IN THE CUTTERBAR

- 1) Keep the machine in the transport position (tractor engine switched off).
- 2) Lift up the front protector (see section "ACCESS TO CUTTERBAR" page 34).
- 3) For security reasons, hook the stop chain (C) as high as possible (photo 59).
- 4) Remove the inner skid shoe (10) (photo 59).
- 5) Remove the left filler plug and its washer (13 - 14) (fig. 60)
- 6) Remove the magnetic drain plug and its washer (11 - 12) (photo 59 and fig. 61) and **drain oil into an appropriate container** (photo 59).
- 7) Clean the magnetic drain plug and its washer (11 - 12) and then put them back in place.
- 8) Pour the correct quantity of oil through the opening of the filling plug (13) (fig. 60).
- 9) Clean the left filler plug and its washer (13 - 14) (fig. 60) and install it back in place.

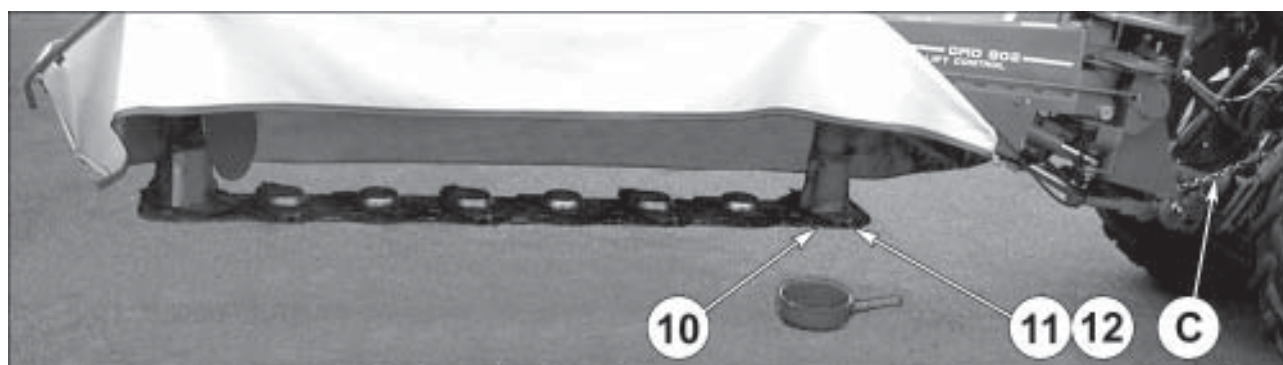

59

CHECKING OIL IN THE CUTTERBAR (fig. 60 and 61)

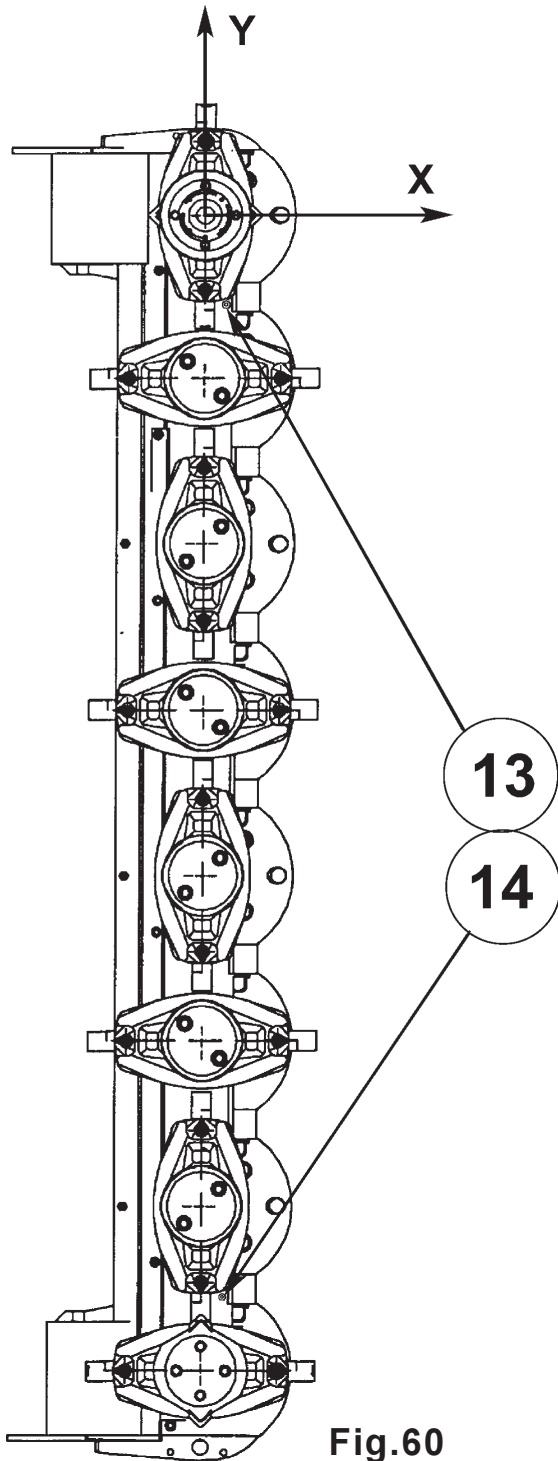

Cutterbar oil level can be checked by measuring oil level through both filler plugs (13 - 14) when the cutterbar is perfectly horizontal lengthways and crosswise (X and Y axes). Use a spirit level to ascertain that this is the case.

Correct oil level is 6 to 7 mm at both filler plugs (fig. 61).

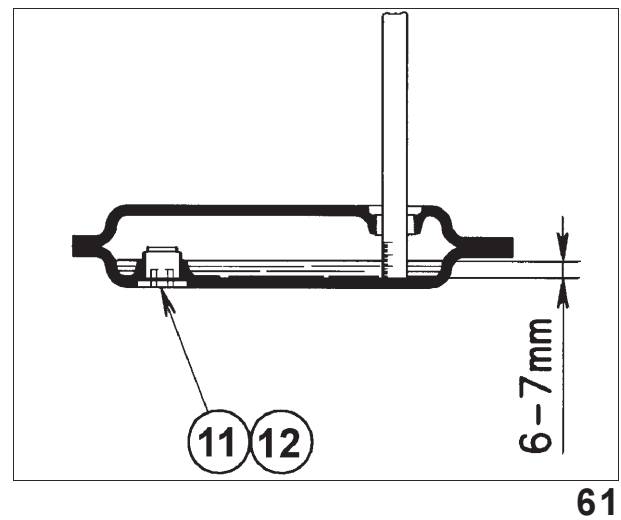

If in doubt as to the amount of oil contained in the cutterbar, do not add oil. Drain the oil completely and refill with the prescribed quantity.

NOTE : Provided above instructions are strictly observed, there is no cause for alarm if it is found that the transmission case is very hot to touch by hand, provided that the discs turn freely by hand.

Attention : Make sure that the tractor engine is shut off, ignition key removed and PTO shaft disconnected before carrying out this operation.

DRAINING AND REFILLING THE LATERAL GEARBOX (fig. 62)

- Remove both guards (15)
- Remove drain plug (16) and let the old oil drain into an appropriate container

Pour oil into dipstick plug hole (17). Periodically check that oil level is between dipstick mark and the bottom of the dipstick.

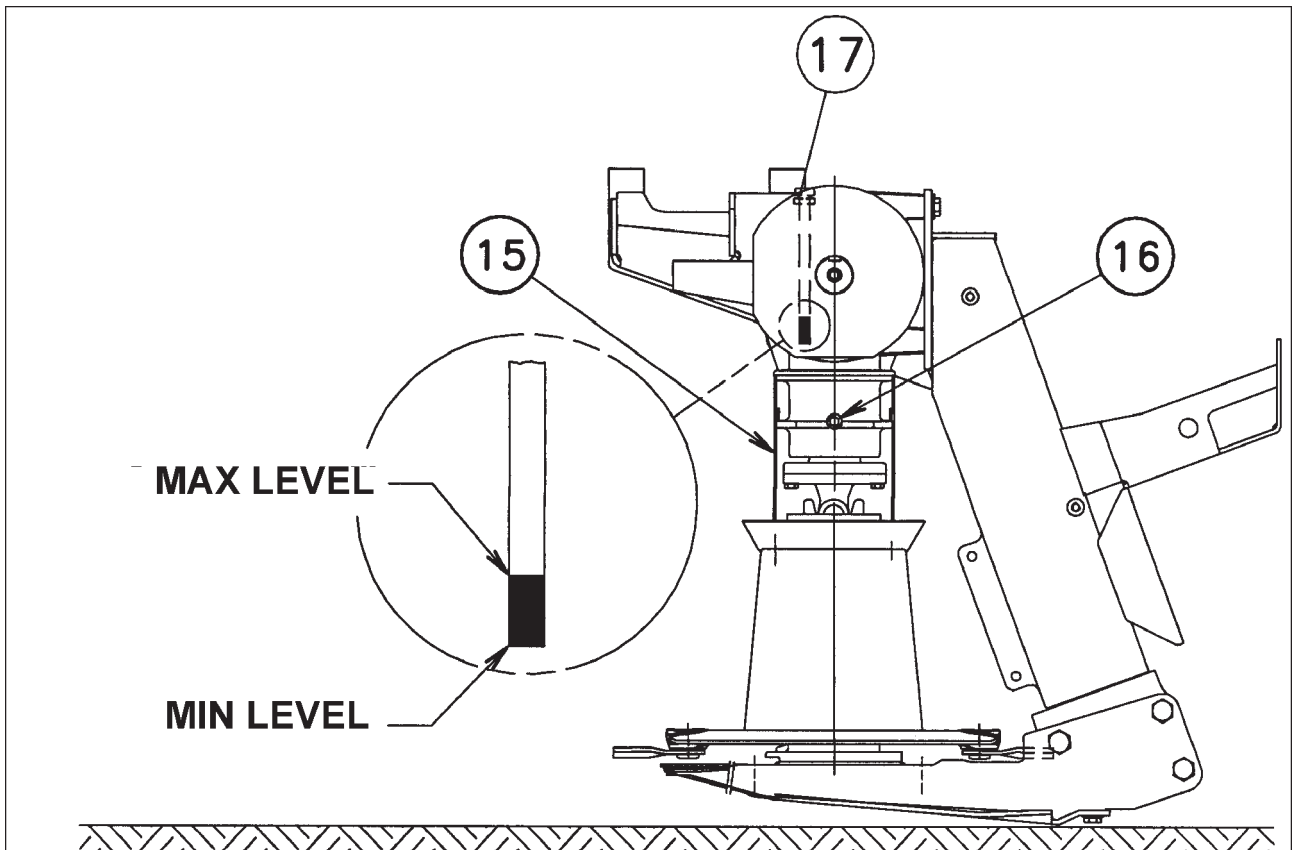

62

DRAINING AND REFILLING THE CENTRAL GEARBOX (fig. 63)

To drain central gearbox oil, proceed as follows :

- remove drain plug (19) and **let the old oil drain into an appropriate container.**

Pour oil into filler plug hole (20). Periodically check oil level:

- Oil level is correct when the oil reaches the edge of hole (20).

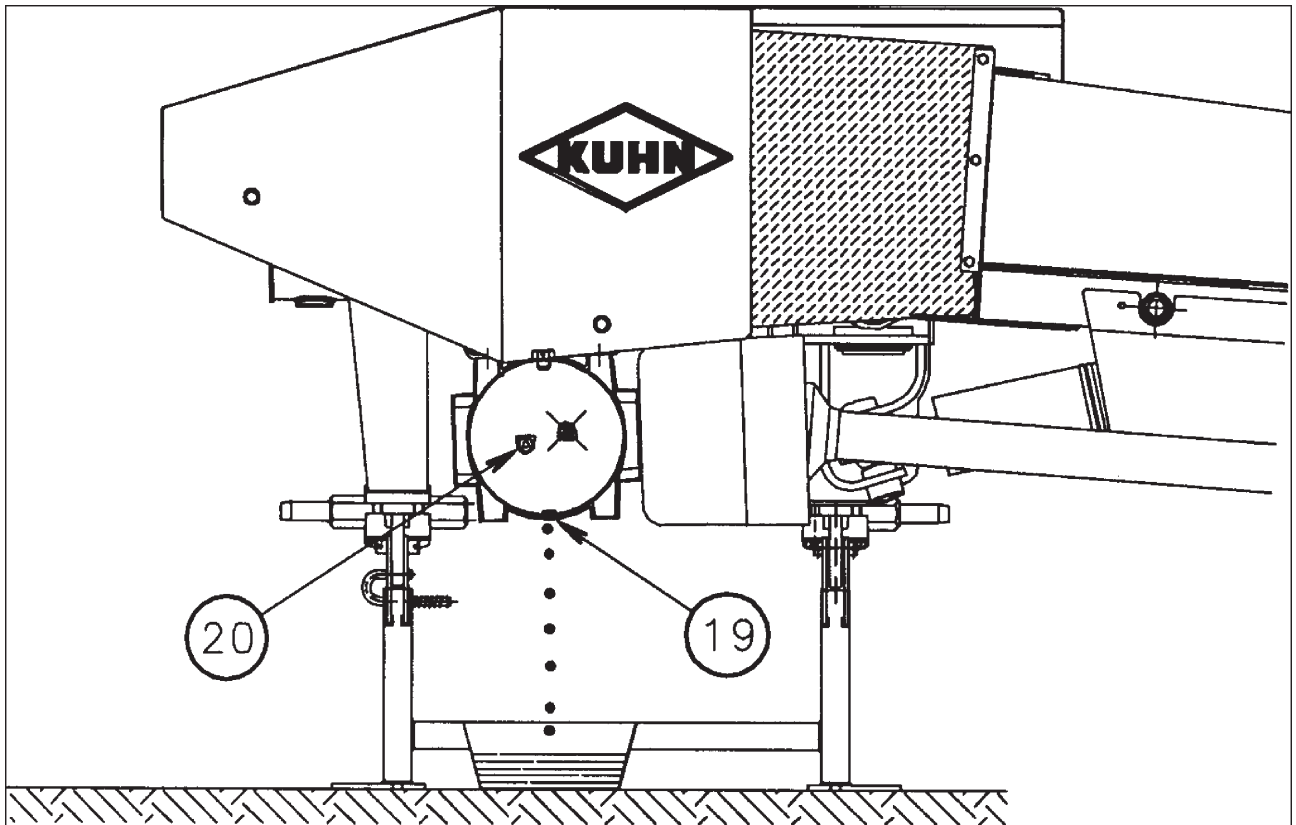

63

GREASE FITTING

Clean fittings before applying grease. Oil all pivot and linkage points after every 50 hours of operation.

a) P.T.O. shafts

Grease every 8 hours with SHELL Multi-Purpose grease NLGI grade 2 the PTO yoke bearings and telescopic drive tubes of the primary and secondary PTO shafts (figure 64).



To grease the secondary PTO transmission shaft, place the machine in the working position and remove the tractor ignition key.

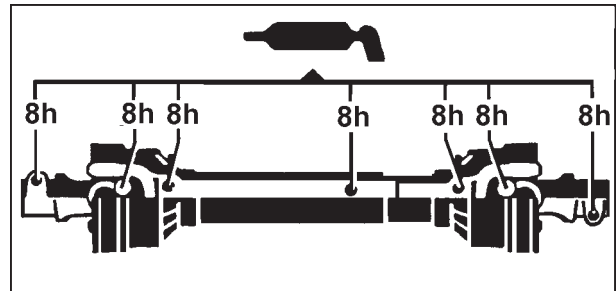

64

The grease zerks of the secondary PTO shaft U-joints, torque limiter and free wheel are accessible through openings (3) of guard (4) (photo 65).

Important note : The telescopic tubes of the secondary PTO shaft are lubricated through grease zerk (1). To gain access to this grease zerk, slide the black collar (2) towards the right and rotate the PTO shaft to align the grease zerk with the oblong hole of the outer guard tube (photo 65). Slide the black collar (2) back in proper location when lubrication has been completed.

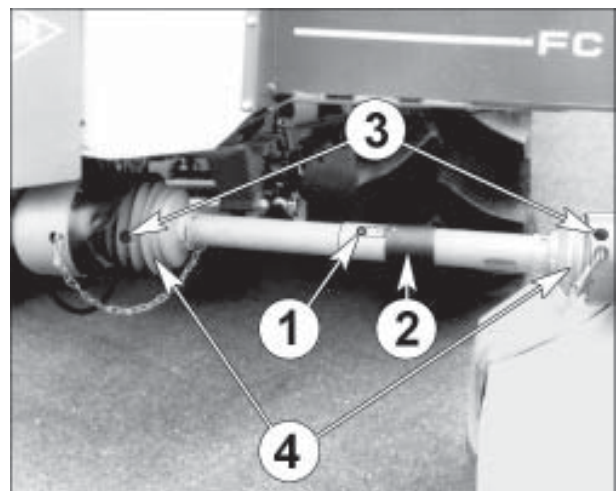

65

b) Lift cylinder front ball joint (photo 66)

Make sure to oil regularly the ball joint (5) of lift cylinder (6) (every 30 hours in normal conditions of use).

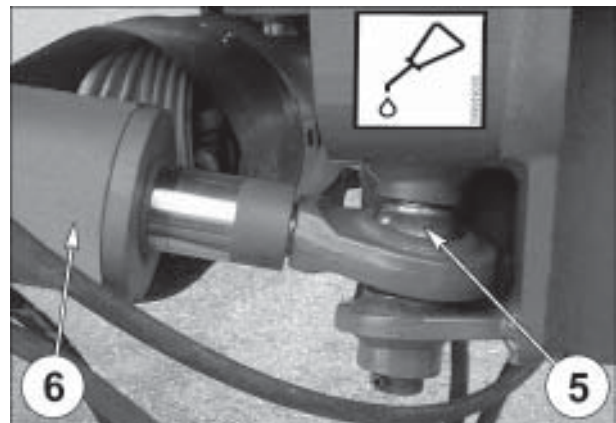

66



The recommended grease and oil change periods are based on normal field and work conditions. Severe or unusual conditions may require more frequent lubrication or oil changes.



Respect specified oil quantities and grades : SAE 80 W EP (GL4) oil only.

(In certain countries SAE 80 W EP (GL4) oil may not be available. In this case a GL 4 or GL 5 grade SAE 80 W 90 oil is an acceptable substitute. Never use a straight EP 90 oil).

42

OPTIONAL EQUIPMENT

1. PTO SHAFT YOKE 1 3/8" - 21 SPLINES No 4603 256

This yoke is available for tractors with 1 3/8" - 21 splines PTO shafts (photo 67).



67

2. SIDE DEFLECTORS (photos 68 and 69) (Kit no. 103 6300)

The side deflectors are recommended for mowing dense and down crops with long stems.

Fit the side deflectors (L and L') on the cutterbar stiffener (R') on the outside of the left and right carrying frame (M and M'), using 4 original hexagonal screws (H) (M16x70) and 4 original self-locking nuts (M16) (torque 30 daNm / 220 ft.lbs), as shown on photos 68 and 69.

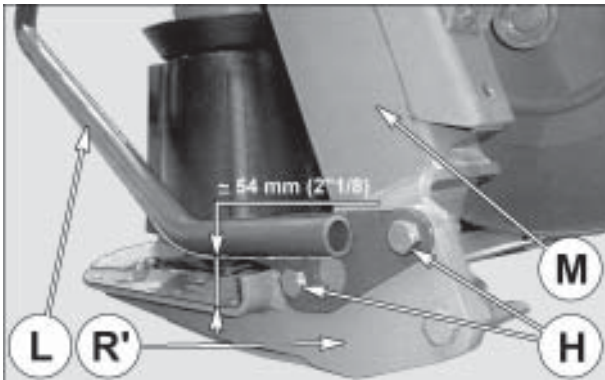

68

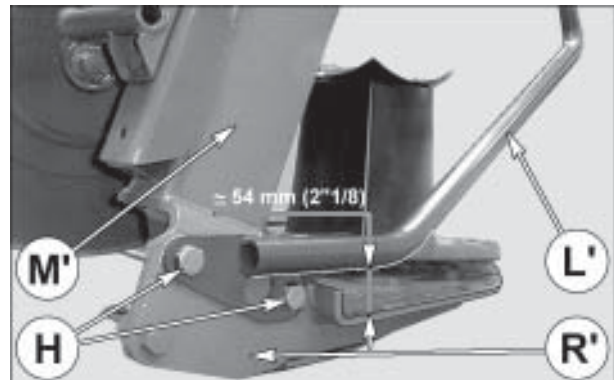

69

STORING THE MULTIDISC MOWER

AT THE END OF THE SEASON

- Thoroughly clean the multidisc mower.
- Drain oil from all gearcases and cutterbars and refill with the prescribed quantity of the correct grade oil. Apply grease to all fittings as described in the lubrication section (see page 39).
- Repaint the rusted parts of the machine and all areas where the paint has worn off.
- Store the machine with the cutterbar in operating position in a dry place.

AT THE BEGINNING OF THE SEASON

- Check the torque limiter for good function (see page 22).
- Inspect all knives and the hardware used to hold them in place (see the corresponding section, pages 35 and 36).
- Check that all nuts and bolts are sufficiently tightened.
- **READ THIS OPERATORS MANUAL ONE MORE TIME.**

TROUBLE SHOOTING GUIDE

PROBLEM	CAUSE	REMEDY
Uneven stubble	Dull or bent knives	Replace knives (see page 37)
	Knives not installed correctly	Make sure that the arrow on the knife upper face is pointing in the direction of rotation of the disc (page 37)
	Low PTO speed (<i>rotational frequency</i>)	Increase engine speed (<i>rotational frequency</i>) to run PTO at 1000 rpm (<i>min⁻¹</i>)
Soil built up in front of cutterbar	Too much cutterbar down pressure	Increase accumulator pressure (see page 26)
	Very wet conditions	Adjust main frame height by shortening chain as necessary (see page 20)
Cutterbar not floating	Main frame setting incorrect	Adjust main frame as described on page 20
	Excessive ground speed	Select a lower gear
	Insufficient ground pressure	Reduce accumulator pressure (page 26)
Insufficient cutterbar ground clearance in "headland turn" position"	Incorrect levelling rod adjustment	Readjust levelling rods (see page 19)
Excessive cutting unit sway in transport	Incorrect transport stopper adjustment	Readjust transport stopper (see pages 32 and 33)

SOUND LEVELS

Sound levels given out by : GMD 802-902 Multidisc mowers

Sound levels have been measured in accordance with the measuring methods as defined in :

HM Agricultural Inspectorate
AGRICULTURAL MACHINERY NOISE
Legislation and guidance on methods of testing
(Annex to AIC 1896/117 REV)
February 1988
Health and Safety Executive

The method employed corresponds to the method No. 4 in this document. Unspecified testing conditions comply with ISO 5131 standard.

Measuring equipment conforms to NF S 31-009 standard. The tractors used have a power of 100 kW.

A-weighted emission sound pressure level L (A) eq inside tractor cab (with closed windows) :

Tractor only	71.0 dB (A)
Tractor + machine	74.2 db (A)

LIMITED WARRANTY

KUHN S.A. of 4 Impasse des Fabriques, 67706 SAVERNE CEDEX, France (hereinafter called the «Company») warrants, in accordance with the provisions below, to each original retail purchaser of KUHN new equipment of its own manufacture, from an authorized KUHN dealer, that such equipment is, at the time of delivery to such purchaser, free from defects in material and workmanship and that such equipment will be warranted for a period of one year starting from the date the goods are delivered to the end user and during this period up to a limit of 500 hours use, providing the machine is used and serviced in accordance with the recommendations in the Operator's Manual.

THESE CONDITIONS ARE SUBJECT TO THE FOLLOWING EXCEPTIONS :

1. Parts of machines which are not of our manufacture i.e. tyres, belts, P.T.O. shafts, clutches etc., are not covered by this Limited Warranty but are subject to the warranty of the original manufacturer. Any claim falling into this category will be taken up with the manufacturer concerned.
2. Warranty claims applying to these types of parts must be handled in the same way as if they were parts manufactured by KUHN. However, compensation will be paid in accordance with the warranty agreement of the manufacturer concerned in as much as the latter justifies such a claim.
3. This Limited Warranty will be withdrawn if any equipment has been used for purposes other than for which it was intended or if it has been misused, neglected or damaged by accident or let out on hire. Nor can claims be accepted if parts other than those manufactured by us have been incorporated in any of our equipment. Furthermore, the Company shall not be responsible for damage in transit or handling by any common carrier and under no circumstances within or without the warranty period will the Company be liable for damages for loss of use or damages resulting from delay or any consequential damage.

We cannot be held responsible for loss of earnings caused by a breakdown or for injuries either to the owner or to a third party, nor can we be called upon to be responsible for labor charges, other than originally agreed, incurred in the removal or replacements of components.

THE CUSTOMER WILL BE RESPONSIBLE FOR AND BEAR THE COSTS OF:

1. Normal maintenance such as greasing, maintenance of oil levels, minor adjustments, etc.
2. Transportation of any kind of any KUHN product to and from the place the warranty work is performed.
3. Dealer travel time to and from the machine or to deliver and return the machine from the workshop for repair.
4. Dealer travelling costs.

Parts defined as normal wearing items are listed as follows and are not in any way covered under this Limited Warranty :

V belts, discs, knives, wear plates, disc guards, tires, torque limiters, hydraulic hoses, pitman shafts, swath sticks, blades, tines and tine holders.

KUHN Limited Warranty will not apply to any product which is altered or modified without the expressed permission of the Company and/or repaired by anyone other than Authorized Service Distributors or Authorized Service Dealers.

LIMITED WARRANTY IS DEPENDENT UPON THE STRICT OBSERVANCE BY THE PURCHASER OF THE FOLLOWING PROVISIONS :

- That this Limited Warranty shall not be assigned or transferred to anyone unless the Company's consent in writing has first been obtained.
- The warranty/product registration form has been correctly completed by dealer and purchaser with their names and addresses, dated, signed and returned to the appropriate address as given on the warranty/product registration form.
- The claim form sent to KUHN has been correctly completed stating:
 - * dealer's name and address
 - * owner's name and address
 - * type of machine
 - * machine serial number
 - * delivery date to buyer
 - * date of failure
 - * tractor make and type
 - * description of the failure and its cause
 - * quantity, reference number and name of the damaged parts
 - * reference number, quantity and date of the invoice for the replacement parts.
- The judgement of the Company in all cases of claims under this Limited Warranty shall be final and conclusive and the purchaser agrees to accept its decisions on all questions as to defect and to the exchange of any part or parts.
- That all safety instructions in the Operator's Manual shall be followed and all safety guards regularly inspected and replaced where necessary.

No warranty is given on second-hand products and none is to be implied. Persons dealing in the Company's products are in no way legal agents of the Company and have no right or authority to assume any obligation on their behalf, express implied, or to bind them in any way.

KUHN S.A. reserves the right to incorporate any change in design in its products without obligation to make such changes on units previously manufactured.

Moreover, because of the constant progress in technology, no guarantee is given to the descriptions of equipment published in any document by the company.

DISCLAIMER OF FURTHER WARRANTY

There are no warranties, expressed or implied, except as set forth above. There is no warranty of merchantability. There are no warranties which extend beyond the description of the product contained herein. In no event shall the company be liable for indirect, special or consequential damages (such as loss of anticipated profits) in connection with the retail purchaser's use of the product.



This machine complies with the safety requirements of the European machinery directive.



The Operator should respect all Health and Safety regulations as well as the Highway Code. For your own safety, use only genuine KUHN spare parts. The manufacturer disclaims all responsibilities due to incorrect use or non-compliance with the recommendations given in this manual.



**For your safety
and to get the best from your machine,
use only genuine KUHN parts**

KUHN S.A. 4 Impasse des Fabriques F - 67706 SAVERNE CEDEX (FRANCE)
Tél. : + 33 (0) 3 88 01 81 00 - Fax : + 33 (0) 3 88 01 81 03
www.kuhnsa.com - E-mail : info@kuhnsa.com
Société Anonyme au Capital de 19 488 000 Euros

Printed in France by KUHN